



«TiSO-PRODUCTION» Company

**INDOOR SINGLE
FULL-HEIGHT TURNSTILE
T1.1.BYC.CC**



**OPERATION MANUAL
AUIA.436 OM (рев.1.0)**

2018

CONTENTS

INTRODUCTION	3
WARNINGS TO THE CUSTOMER	4
ON SAFE OPERATION OF THE TURNSTILE.....	4
GENERAL WARNINGS	4
1 DESCRIPTION AND OPERATION	5
1.1 General Information and Designation.....	5
1.2 Specifications.....	6
1.3 Configuration and Completeness of Delivery.....	6
1.4 Design and operation	7
1.5 Instrumentation, tools and accessories.....	9
1.6 Description and operation of controller as component of the turnstile.....	10
2 INTENDED USE.....	20
2.1 Operation limitations	20
2.2 Layout and installation.....	20
2.3 Preparation for use	26
2.4 Contingency actions.....	27
3 MAINTENANCE	27
3.1 General instructions	27
3.2 Safety Measures	27
3.3 Maintenance procedure.....	27
4 ROUTINE MAINTENANCE.....	28
4.1 General instructions	28
4.2 List of possible malfunctions.....	29
4.3 Postrepair checkout.....	29
5 TRANSPORTATION AND STORAGE.....	29
5.1 Turnstile storage.....	29
5.2 Turnstile transportation.....	29
6 DISPOSAL	30
7 MANUFACTURER'S WARRANTY AND TERMS OF WARRANTY MEAINTENANCE ...	30
Annex A_Design, overall and fitting dimensions_of Indoor Single Full-Height Turnstile	32
Annex B_Control panel and connection diagram.....	35
Annex C_Wiring Diagram of the turnstile.....	38
Annex D.1Wiring diagram of the turnstile connection to access control system (ACS) in pulse mode.....	39
Annex D.2_Wiring diagram of the turnstile connection to access control system (ACS) in hold mode.....	40
Annex D.3_Diagram of the turnstile connection to fire alarm (FA).....	41
Annex D.4_Wiring diagram of the turnstile connection to fire alarm system (FAS).....	42
Annex D.5_Wiring diagram of the turnstile connection to control panel.....	43

INTRODUCTION

This Operation Manual (hereinafter referred to as the OM), covers the Indoor Single Full-Height Turnstile with servomotor (hereinafter referred to as the turnstile). The Operation Manual contains information about design, specifications, installation, proper operation and maintenance of the turnstile.

This Operation Manual is prepared in compliance with the specification requirements TU U 31.6-31.6-32421280-003:2010.

The turnstile should be serviced only by the qualified staff having the relevant class of permit to work with electrical facilities with voltage up to 1000V, who carefully studied this Operation Manual, obtained safety instructions and trained for operation and maintenance of the turnstile.

Reliability and durability of the turnstile operation is provided with observation of modes and conditions of transportation, storage, installation and operation. So, fulfillment of all requirements specified in this document is mandatory.

In view of regularly performed works on improvement of the product, its design can be modified without degradation of parameters and quality of the product.

Depending on the purpose and design features of the turnstile, the following pattern of product reference designation is accepted:

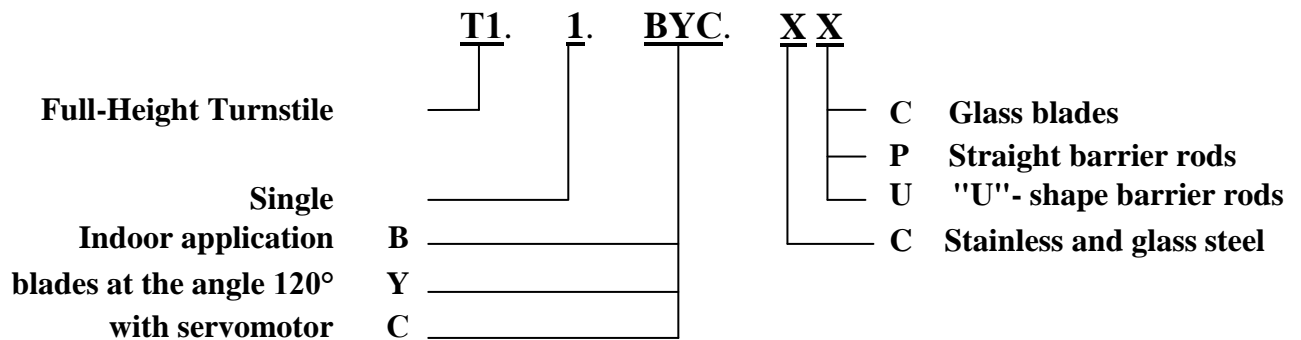

Example of reference designation of the Single Full-Height Turnstile with servomotor, glass blades and stainless steel and glass housing when the turnstile

T1.1.BYC.CC TU U 31.6-32421280-003:2010 is ordered.

WARNINGS TO THE CUSTOMER ON SAFE OPERATION OF THE TURNSTILE

These warnings are designed for ensuring of safety during operation of the turnstile to prevent violation of safety characteristics by improper installation or operation. These warnings are aimed at drawing attention of the customer to safety problems.

GENERAL WARNINGS

The Operation Manual is an integral part of the product and it should be handed over to the customer. The OM should be kept for later use and consulted for clarifications if required. If the turnstile is resold, handed over to another owner or transported to another place, make sure that the OM is enclosed to the turnstile to be used by new owner and/or maintenance staff during installation and/or operation.

Safety measures and requirements specified in this in this OM must be observed:

- the turnstile must be connected to ground loop prior to operation;
- the turnstile should be connected to AC network with parameters specified in the paragraph 1.2 «Specifications»;
- inspection, adjustment and repair should be performed only after the turnstile is deenergized.

After purchasing of the turnstile it should be unpacked and its integrity should be checked. In case of doubt in integrity of the turnstile it should not be used and the customer should refer to the supplier or to the manufacturer.

Packing accessories (wooden pallet, nails, clips, polyethylene bags, cardboard etc.) as potential sources of hazard must be removed to unacceptable place prior to proper use of the turnstile.

As electric shock protection device the turnstile is related to 01 protection class according to the GOST (State Standard) 12.2.007.0-75 and is not intended for operation in explosive and fire-hazardous areas by the «Rules for design of electrical installations».

Using of the turnstile for unintended purpose, improper installation, nonobservance of conditions of transportation, storage, installation and operation specified by this OM, may result in damage to people, animals or property for which the manufacturer is not responsible.

1 DESCRIPTION AND OPERATION

1.1 General Information and Designation

1.1.1 The turnstile is designed for pedestrian movement control at access points of industrial enterprises, banks, stadiums, administrative facilities etc. under actuation of control signals (coming from magnetic card readers, keypad etc.) of access control system or manually (from control panel).

Traffic flow capacity of the turnstile without personal identification is at least 20 persons per minute.

1.1.2 Dimensions and weight of the turnstile correspond to the values are specified in the Table 1.

Table 1

Designation of modification	Dimensions, mm			Max. weight, kg
	<i>H</i>	<i>L</i>	<i>B</i>	
T1.1.BYC.CC	2310	1430	1442	470

1.1.3 The parameters defining operation conditions according to GOST 15150-69 are specified in the Table 2.

Table 2

Operation conditions	For climatic version	Parameter value
Ambient temperature	NF4	+ 1°C to + 40°C
Relative humidity		80% at + 25°C
Ambient temperature allowable pressure		84 to 106,7kPa
Transportation temperature range		- 50°C to + 50°C
Storage temperature range		+ 5 to + 40°C
Group of mechanical application		L3
Altitude above sea level		up to 2000 m
Environment		Explosion-proof, does not contain current-conducting dust, aggressive gases and vapours in concentration destroying isolation and metals, disturbing normal operation of the equipment installed in turnstiles
Installation site		In enclosed spaces in the absence of direct impact of precipitations and solar radiation
Running position		Vertical, deviation from vertical position no more than 1° to any side is tolerated

1.1.4 Reliability indices:

– mean time to repair (without delivery time of spare parts, tools and accessories) – at most 6 hours;

– mean time to failure – at least 1 500 000 accesses;

– mean service life between overhauls – at least 10 years.

1.2 Specifications

Principal parameters of the turnstile are specified in the Table 3.

Table 3

<i>Parameter description</i>	<i>Unit measure</i>	<i>Parameter value</i>
Traffic flow capacity in free access mode is at least	man/min.	20
Max. passage width	mm	650
Supply voltage:		
– AC power supply (primary)	V Hz	100÷240 ~ 50/60
– DC power supply (secondary)	B	12
Max. power consumption	V·A	150
Index of protection according to EN 60529	–	IP41

1.3 Configuration and Completeness of Delivery

1.3.1 Turnstile design

1.3.1.1 Design of the Single Full-Height Turnstile includes the following principal devices and components (see Appendix A):

- walls;
- frame;
- rotor;
- roof with control mechanism;
- LED displays;
- electrical equipment;
- control panel.

1.3.1.2 The turnstile modification with glass blades (reference designation T1.1.BYC.CC).

Upon request the customized applications can be done:

- turnstile modification with straight barrier rods (reference designation T1.1.BYC.CP);
- turnstile modification with "U"- shape barrier rods (reference designation T1.1.BYC.CU).

1.3.1.3 The turnstile is manufactured from polished or brushed stainless and glass steel (reference designation T1.1.BYC.CC).

Modification, overall and installation dimensions of the turnstile are shown in the Appendix A.

1.3.2 Completeness of Delivery

Completeness of delivery is specified in the Table 4.

Table 4.

Name of product	Product designation/parameters	Quantity, piece	Notes
Indoor Single Full-Height Turnstile	T1.1.BYC._____	1 kit	–
<u>Components</u>			
Control panel	AUIA.114.02.00.00	1	–
Frame*		1	–
Frame installation kit	Screw M12 x 40.019 GOST 11738-84	11	To be delivered along with frame

	Washer 12.65G.019 GOST 6402-70	11	
Battery*	12V; 17A·h	1	Backup Power Supply
Turnstile installation kit (without frame)	Redibolt 92F112A2-0 (12×120 M10)	9	–
Operation manual (Certificate)	AUIA.436 OM	1	–
Packing	–	1	–
* Optional			

When ready-to-install turnstile is ordered it is delivered by one package.

1.4 Design and operation

1.4.1 Turnstile design

1.4.1.1 Prefabricated arched structure (see Appendix A) consists of two walls, frame and rotor. The top connecting bar of the structure is roof 1, inside which the turnstile control mechanism and electrical equipment (power supply and control unit, battery, controllers etc.) are located.

1.4.1.2 Revolving rotor, divided into three sectors, each of 120°, is located between the walls. The upper part of rotor is linked with shaft of control mechanism through halfcouple. Support of revolving rotor and walls are fixed to the frame or floor by means of Redibolt.

1.4.1.3 The control mechanism design (see the Figure 1) consists of bottom and upper plates (1 and 2), on which primary components of structure are located.

On the shaft between the plates ratchet gears (3 and 4) are located, which are locked with latches (5 and 6). In interlocking position with ratchet gears the latches are pushed by springs (7 and 8). Ratchet gears are disconnected by means of solenoids (9 and 10), which when actuated provide rotation of the relevant latches and unlocking of the relevant ratchet gear.

Rotor is driven to initial position (when ratchet gear with its tooth abuts against latch) by servomotor.

Control sensors of rotor initial position and direction of its rotation are optocouples (18, 19) operating in consolidation with sprocket disk (16, 17) rigidly connected to the shaft of ratchet gears.

Locks (23 and 24) are designed for manual unlocking of the turnstile.

Position of mechanical unlocking locks is controlled by microswitches (25 and 26).

Solenoids (9 and 10) operate in «boost» mode (i.e. supply of additional voltage up to the level of 24V-27V) provided by microswitches (27 and 28) depending on position of latches

1.4.1.5 LED displays are located on posts of the turnstile and on container at the entrance and are designed for visual display of information about definition and execution of instructions coming from control system (ACS, control panel or keypad) to actuating mechanisms of the turnstile.

1.4.1.6 Control panel is made as small desktop device in plastic case designed for setting and indication of operation modes when the turnstile is operated manually. Control panel and its connection diagram are shown in the Appendix B.

1.4.1.7 In order to ensure operation of the turnstile as part of access control system (ACS) the following components are used as elements of this system:

- Complex of ACS technical means;
- ACS software;
- Card, badge etc. readers;

- Cards, badges etc;
- Airlocking keypad;
- Technical means of permit issuance.

The Manufacturer delivers the listed above as agreed by the parties under separate contract.

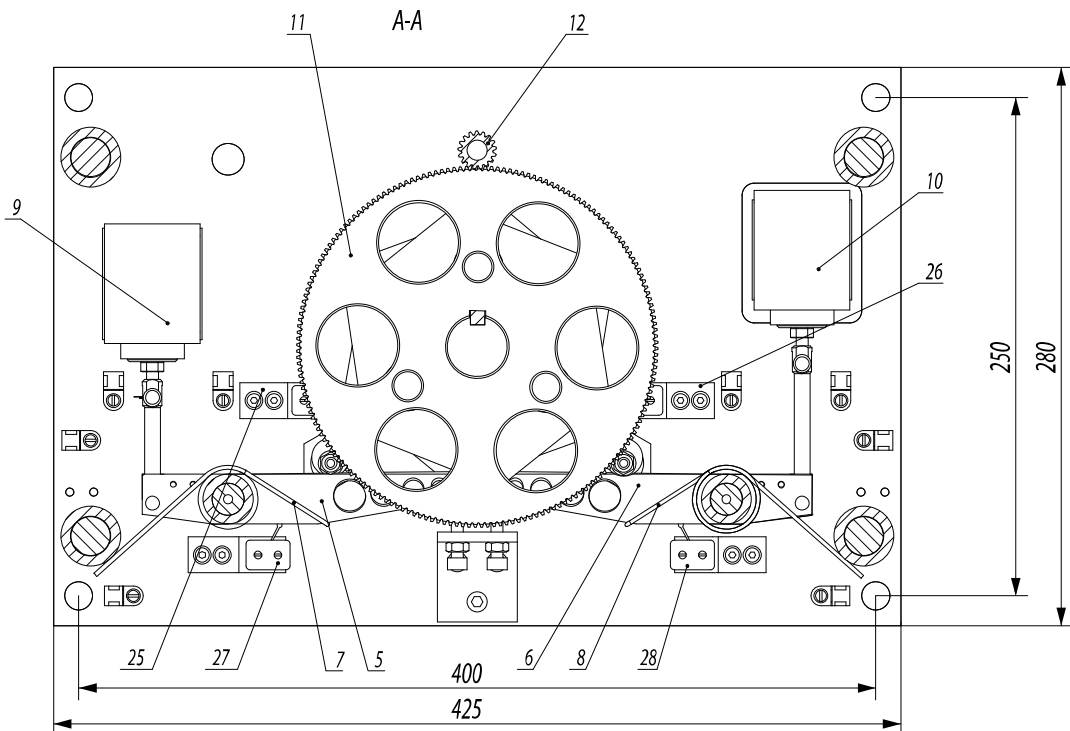
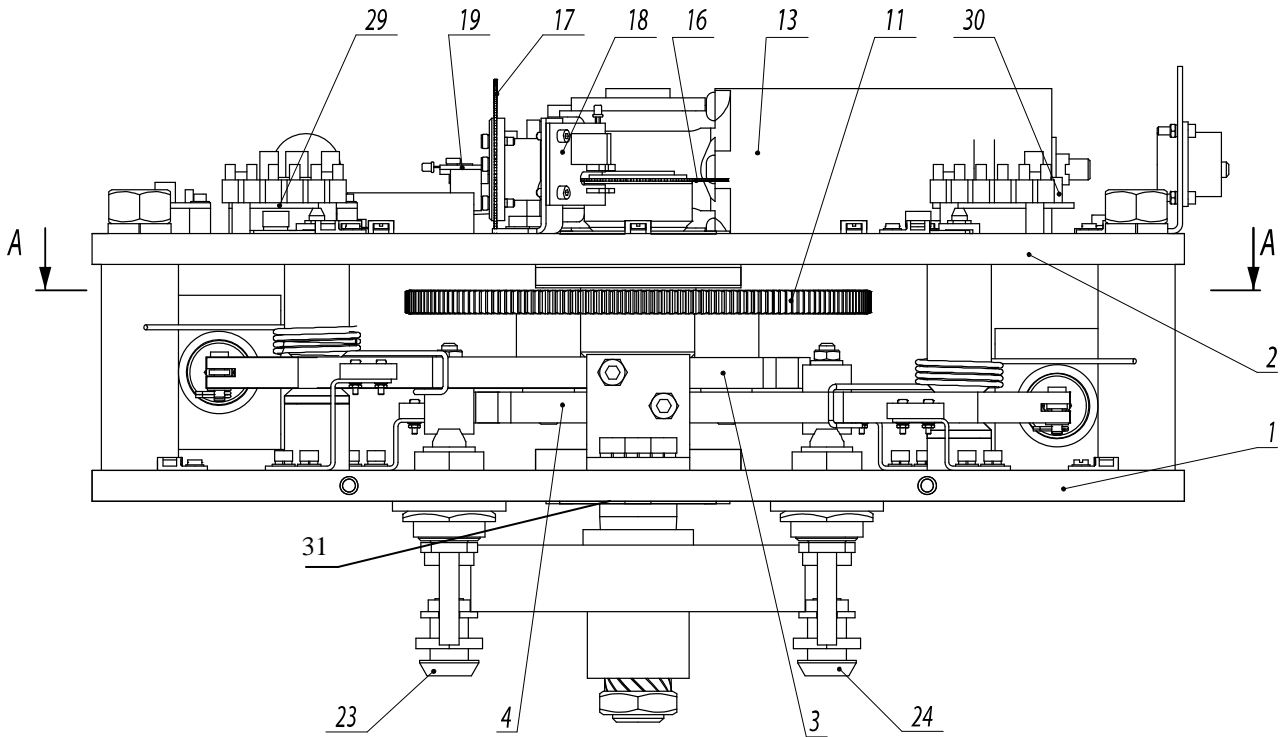

- | | |
|-----------------------|------------------------|
| 1 – bottom plate; | 12 – drive pinion; |
| 2 – upper plate; | 13 – gear motor; |
| 3, 4 – ratchet gears; | 16,17 – sprocket disk; |
| 5, 6 – latches; | 18, 19 – sensor card; |

7, 8 – springs;	23, 24 – locks;
9, 10 – solenoids;	25, 26, 27, 28 – microswitches;
11 – driven pinion;	29, 30 – converters;
	31 – half-coupling

Figure 1 – Control mechanism

1.4.2 Principle of operation

1.4.2.1 In the initial state (when solenoids of control mechanism are deenergized) rotor is locked from rotation in both directions.

1.4.2.2 When access enabling command is given to controller in one of directions:

Green arrow is lit on LED display;

The relevant solenoid is energized;

The turnstile is unlocked in the relevant direction and the turnstile accessor is able to bring rotor out of initial position manually in the direction of access. Due to servomotor rotor revolves independently to 120° and stops in fixed position.

1.4.2.3 As soon as rotor starts revolving the red symbol « X » is lit on the LED display (Figure.2).

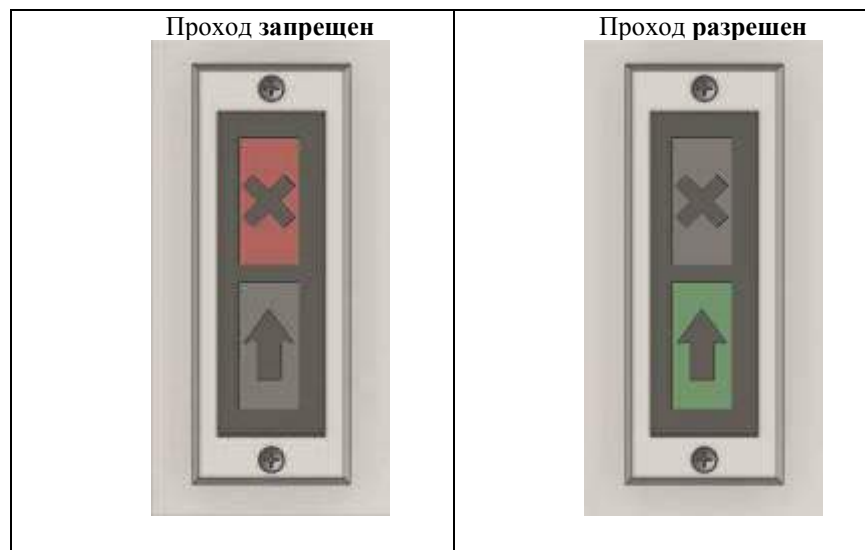

Figure.2 - Displays of the status of a turnstile to indications

More detailed description of the turnstile operation modes is given in the paragraph 1.8 «Description and operation of controller as component of the turnstile».

1.4.2.4 12V DC power voltage is provided by power supply unit.

1.4.2.5 When mains power supply is off, the turnstile is automatically switched to the power supply from 12V, 17A•h battery (optional), which ensures the turnstile's operation within at least 2 hours.

1.4.2.6 The turnstile's wiring diagram is shown in the Appendix C.

1.5 Instrumentation, tools and accessories

Dedicated tools are not required for the turnstile installation (multi-purpose measurement instrumentation and installation tools are sufficient).

- puncher;
- concrete drills (according to diameter of anchors included in the turnstile scope of delivery);
- extension cord;
- kit of end and pin wrenches;

- kit of hexagons;
- kit of screwdrivers;
- hammer;
- multimeter (tester);
- measuring tape;
- marker;
- pliers, side cutters;
- builder's level.



Figure 2- Tools and accessories for layout and installation

1.6 DESCRIPTION AND OPERATION OF CONTROLLER AS COMPONENT OF THE TURNSTILE

1.6.1 The turnstile controller PCB.112.21.20.00

1.6.1.1 The controller is performed on the (104x68)mm card. Field-effect transistors are used to control solenoids and indicators.

19 light emitting diodes are installed on the controller card. Their purpose is as follows:

- 5 light emitting diodes display state of the external connection inputs «INP1» ÷ «INP5»;
- the light emitting diode «POWER» displays existence of 5V power supply voltage;
- the light emitting diode «OPERATE» displays operating capacity of microprocessor;
- 7 light emitting diodes display state of the external connection outputs «OUT1» ÷ «OUT7»;
- 3 light emitting diodes «SENSOR» display state of rotor position sensor;
- the light emitting diodes «RX» and «TX» display transceiving on serial port.

40 terminal clips for connection of wires are installed on the card, 14 of which are designed for external connections and the rest are designed for connection to the turnstile units or are standby.

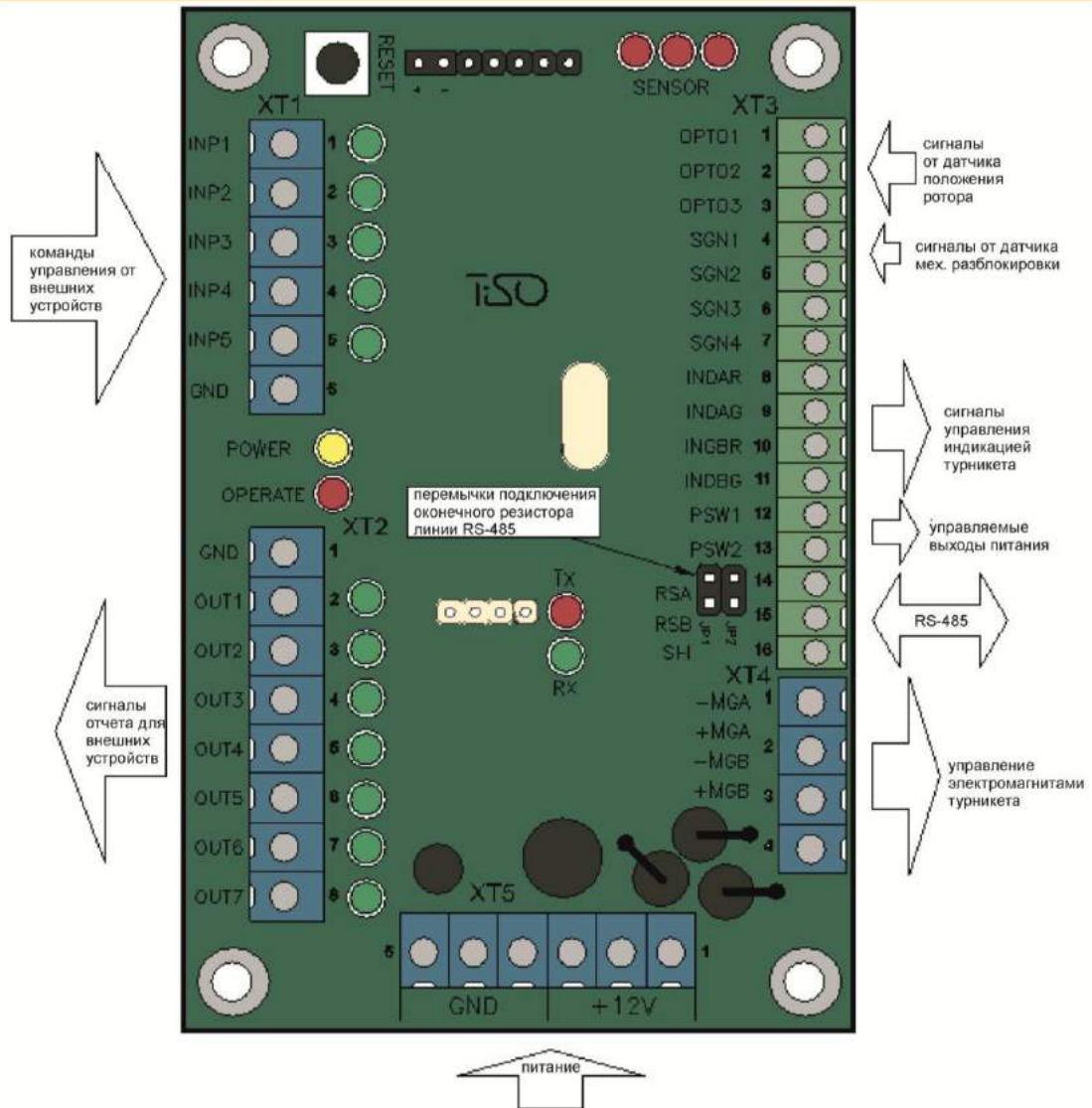

Figure 2 – Appearance of the controller PCB.112.21.20.00

1.6.1.2 Technical features

The controller technical features are specified in the Table 5.

Table 5

Parameter description	Parameter value
Number of inputs for reception of control commands	5
Number of signal outputs	7
Type of inputs	logical
Type of outputs	open collector
Voltage of logical «1»	(3÷5)V
Voltage of logical «0»	(0÷2,2)V
Maximum peak voltage supplied to the inputs «INP1» ÷ «INP5»	15V
Peak voltage switched by transistors of signal output transistors	50V
Peak current switched through signal outputs	0,1A
Power supply voltage of controller	(9÷15)V
Peak consumption current	0,15A
Number of signal transeiving serial ports (RS-485)	1
Climatic version and category of location according to the GOST 15150-69	NF4

Appearance of the controller is shown in the Figure 2.

1.6.1.3 Description of operation

The controller operates according to the program entered into memory of microprocessor. Mechanism and LED display of the turnstile are controlled depending on control commands and rotor position sensors based on the logic entered into program. Control commands can be transmitted via RS-485 (from control panel) or logical inputs by means of closing and opening «INP1» ÷ «INP5» on «GND».

Controller (and therefore the turnstile) can be in «INITIAL STATE» (closed for access) or in one of the following access modes:

- «SINGLE ACCESS IN ONE DIRECTION WITHOUT AIRLOCK»;
- «SINGLE ACCESS IN ONE DIRECTION WITH AIRLOCK FUNCTION»;
- «FREE ACCESS IN ONE DIRECTION»;
- «MECHANICAL UNLOCKING IN ONE DIRECTION».

Other operating modes are combinations of various or identical basic modes in different directions:

- Single access in one direction without airlock and any of basic modes in opposite direction.
- Single access in one direction with airlock function and any of basic modes in opposite direction.
- Free access in one direction and any of basic modes in opposite direction.
- Mechanical unlocking in one direction and any of the above modes in opposite direction.

1.6.1.3.1 «INITIAL STATE»

Controller is in this mode if the commands «OPEN A/B» are absent and the turnstile rotor is set to the point 0°, 120° or 240°.

In this mode solenoids are deenergized and rotor is locked. Red inhibit LED display is lit in both directions.

1.6.1.3.2 «SINGLE ACCESS IN ONE DIRECTION WITHOUT AIRLOCK»

In this mode controller unlocks rotor via solenoid in one direction with possibility of its rotation to 120°. It enables turnstile access of one pedestrian without a stop in the point 60° (airlock).

Controller goes to «SINGLE ACCESS IN ONE DIRECTION», if in «INITIAL STATE» it receives the command «OPEN A/B» (active level of signal is given to the input «INP4» or «INP5»). Turnstile is open during action of signal). Command can also come through RS-485.

In this case, if command is received through the input «INP4» or «INP5», controller waits for «START» of rotor rotation during active status of signal on the relevant input «INP4» or «INP5» and if controller has received the command «OPEN A/B» though RS-485, then «START» of rotor rotation is expected before ending of delay «WAITING FOR START OF ACCESS».

Sequence of actions of controller after reception of the command «OPEN A/B» is as follows:

- Delay of «WAITING FOR START OF ACCESS» is initiated.
- Controller energizes solenoid and thus unlocks rotor in the relevant direction.
- LED display corresponding to authorized access is switched from red to green.

If during delay of «WAITING FOR START OF ACCESS» rotor rotation has started, then further behaviour of controller depends on the angle of rotor rotation:

- 6° of rotor rotation – LED display is switched from red to green indicating occupation of access. The output signal «START OF ACCESS A/B» («OUT1» or «OUT2») assumes active status. Delay of «WAITING FOR START OF ACCESS» is cancelled.

- 10° of rotor rotation – status of the relevant input «AIRLOCK A/B» is verified. If command is active, controller goes to the mode «SINGLE ACCESS IN ONE DIRECTION WITH

AIRLOCK FUNCTION». If by this moment the command «AIRLOCK» of the relevant direction has not come, then controller further operates in the mode «SINGLE ACCESS IN ONE DIRECTION WITHOUT AIRLOCK».

- 58° of rotor rotation – the signal «START OF ACCESS A/B» («OUT1» or «OUT2») is cancelled and the signal «AIRLOCK POINT A/B» («OUT5») appears.
- 60° of rotor rotation – when this point is entered rotor can't be returned to the point 0° (in opposite direction) without the command «RETURN» («INP1») being given or actuation of the «FREE ACCESS» mode via RS-485 in opposite direction.
- 64° of rotor rotation – the signal «DETECTION OF ACCESS A/B» («OUT3» or «OUT4») is generated.
- 70° of rotor rotation – the relevant solenoid is deenergized preparing rotor for locking in the point 120° (0° for next access).
- 120° of rotor rotation – the signals «AIRLOCK POINT A/B» («OUT5») and the relevant signal «DETECTION OF ACCESS A/B» («OUT3» or «OUT4») are cancelled and after that availability of the command «OPEN A/B» («OUT3» or «OUT4») corresponding to the current direction of access is verified and if command by that moment is active then controller goes to the «FREE ACCESS» mode.

1.6.1.3.3 «SINGLE ACCESS IN ONE DIRECTION WITH AIRLOCK FUNCTION»

In this mode controller unlocks rotor via solenoid in one direction with possibility of its rotation to 60°. After that rotor can be unlocked in any direction that enables to arrange the second level of identification and authorize completion of access or exit in opposite direction according to identification results.

Controller goes to the mode «SINGLE ACCESS WITH AIRLOCK FUNCTION», if in «INITIAL STATE» the command «AIRLOCK A/B» («INP2» or «INP3») is active. In this case controller, received the relevant command «TO BE OPENED A/B», goes to the mode «SINGLE ACCESS IN ONE DIRECTION WITH AIRLOCK FUNCTION».

The controller also goes to the mode «SINGLE ACCESS WITH AIRLOCK FUNCTION», if the turnstile has started to operate in one of directions in the «SINGLE ACCESS» mode, and when rotor reaches 10° angle the command «AIRLOCK» is activated in the direction of current access and later on access will be with airlock function.

Difference of controller operation in this mode from the mode «SINGLE ACCESS IN ONE DIRECTION WITHOUT AIRLOCK» is as follows:

- When rotor reaches the position 10° controller deenergizes the solenoid of current access and the solenoid of opposite direction, if in opposite direction «FREE ACCESS» is turned on.
- Rotor gets to 60° with two deenergized solenoids that results in its locking.
- After that rotor can be unlocked again in straight direction (the direction of continued access) by cancellation of the relevant command «AIRLOCK» («INP2» / «INP3») or by giving via RS-485 the command «FREE ACCESS» in the current direction. The difference is that having received via RS-485 the command «FREE ACCESS» rotor will not be locked in the current direction in the point 120°.
- From the position «AIRELOCK» rotor can't be unlocked for exit in opposite direction by giving the command «RETURN» (active level of signal on the input «INP1») or by giving via RS-485 the command «FREE ACCESS» in opposite direction. The difference is that having received via RS-485 the command «FREE ACCESS» via RS-485 rotor will not be locked in the point 0°.

1.6.1.3.4 «FREE ACCESS IN ONE DIRECTION»

In this mode rotor can rotate freely in the free access direction. In opposite direction rotor can rotate only up to the nearest locking point, i.e. to 60°. In the «FREE ACCESS» mode LED display of thy relevant direction is blinking green.

Controller is switched to this mode in two cases:

- First – when the command «OPEN A/B» (input «INP4» or «INP5») is kept in active status in the moment of crossing by rotor of the point 120° when «SINGLE ACCESS» is finished.
- Second – immediately after reception of the command «FREE ACCESS» via RS-485 in the relevant direction.

After controller is switched to the «FREE ACCESS» mode the status of the command «AIRLOCK» of the relevant direction is of no importance and output signals «START OF ACCESS», «DETECTION OF ACCESS» and «AIRLOCK POINT» of the appropriate direction are not generated.

Quitting from this mode into «INITIAL STATE» is performed after cancellation of the command «OPEN A/B» or reception of the command «CANCELLATION OF FREE ACCESS» via RS-485. But it occurs not immediately and only when rotor reaches one of the start points 0°, 120° or 240°, i.e. if free access is cancelled during started access then it will be finished as free access.

1.6.1.3.5 «MECHANICAL UNLOCKING»

In this mode rotor can rotate freely in the direction of mechanically unlocked access. It is done in order to enable the turnstile access in case of emergency as well as when standby battery is completely discharged or malfunction of electronic equipment.

The turnstile is switched to this mode by turning of mechanical key. Having received signal from the microswitch related to mechanical key controller goes to the mode «MECHANICAL UNLOCKING» in the appropriate direction. Since in this mode controller is unable to have effect on passage operation, so LED display is identical to free access, that is: green LED display of unlocked access is blinking and red LED display is OFF. No output signals related to mechanically unlocked access are generated.

Quitting from this mode is performed after turning of the key «MECHANICAL UNLOCKING» to initial state.

1.6.1.3.6 «PERMISSION OF SINGLE ACCESS IN BOTH DIRECTIONS»

Since the turnstile, having one rotor, is unable to rotate in both directions at a time, so controller can only unlock rotor in both directions and when access is started in one of directions the opposite direction will be closed.

Controller goes to this mode if it simultaneously receives the commands «OPEN A» and «OPEN B» in «INITIAL STATE». The second signal can also come when the first signal is already active but rotor has not started to rotate.

In this case:

- Controller unlocks rotor in both directions via solenoids.
- Both LED displays are switched from red to green.
- Two delays of «WAITING FOR START OF ACCESS A» are actuated for each access particularly, which are counted from the moment of coming of commands.
- Controller is waiting for starting of access.
- After rotor is turned to 6° in any side, the solenoid of opposite direction will be OFF, LED display will be switched to red and delay of «WAITING FOR START OF ACCESS» of opposite direction will be cancelled.
- Then controller is operating as it is described in the paragraph «SINGLE ACCESS IN ONE DIRECTION».
- If during active status of the signals «TO BE OPENED A» and «TO BE OPENED B» rotor is not turned to any side to the angle > 6°, then controller goes to «INITIAL STATE».

Purpose of the controller contacts designed for connection of peripherals is specified in the Table 6.

Table 6

Connector/contact No.	Description	Direction	Designation	Signal description and parameters
XT1/1	INP1 («RETURN»)	ENTRY	Command «To be opened from locked position in airlock in opposite direction»	1) logical «0» (0÷2,2)V;
XT1/2	INP2 («AIRLOCK A»)	ENTRY	Command «Lock rotor at 60°». Command should be cancelled to unlock rotor in straight direction. If signal is available during entry after rotor reaches 15°, then rotor will be locked at 60°, otherwise rotor will be locked only at 120°	2) logical «1» (3÷5)V;
XT1/3	INP3 («AIRLOCK B»)	ENTRY		3) active level of signal (factory setting) – logical «0»;
XT1/4	INP4 («OPEN A»)	ENTRY	Command «TO BE OPENED FOR SINGLE/FREE ACCESS»; free access appears when entry is kept in active status after timeout waiting for start of access (~ 5 s) is expired or from the moment when rotor reaches the angle 96°	4) voltage on open input < 5V
XT1/5	INP5 («OPEN B»)	ENTRY		1) logical «0» (0÷2,2)V;
XT1/6	GND (common)			2) logical «1» (3÷5)V;
XT2/7	GND (common)			3) active level of signal (factory setting) – logical «0»;
XT2/8	OUT1 («START OF ACCESS A»)	EXIT	Signal is generated by controller when the command «TO BE OPENED» is received and rotor rotation in the same direction is detected	4) voltage on open input < 5V
XT2/9	OUT2 («START OF ACCESS B»)	EXIT		1) type of output – open collector;
XT2/10	OUT3 («DETECTION OF ACCESS A»)	EXIT	Signal is generated by controller when rotor is rotating from 64°	2) peak voltage on privacy key 55V;
XT2/11	OUT4 («DETECTION OF ACCESS B»)	EXIT		3) peak current of public key 100mA;
XT2/12	OUT5 («AIRLOCK POINT»)	EXIT	Signal is generated by controller when rotor reaches the angle 54°	4) resistance of public key (5÷7)Ohm;
XT2/13	OUT6 («ERROR»)	EXIT	Signal is generated by controller when fault of behaviour is detected	5) active level of signal (factory setting) – logical «0»
XT2/14	OUT7 («PASSAGE IS OCCUPIED»)	EXIT	Signal is generated by controller starting from the angle 2° to 118°	
XT3/15	OPTO1	ENTRY	Used for obtaining of information about turnstile	1) logical «0» (0÷2,2)V;

End of the Table 6

Connector/contact No.	Description	Direction	Designation	Signal description and parameters
			rotor position	2) logical «1» – (3÷5)V; 3) active level of signal (factory setting) – logical «0»; 4) voltage on open input < 5V
XT3/16	OPTO2	ENTRY		
XT3/17	OPTO3	ENTRY		
XT3/18	SGN1	ENTRY		
XT3/19	SGN2	ENTRY	Used for obtaining of information about mechanical unlocking of turnstile rotor	
XT3/20	SGN3	ENTRY		
XT3/21	SGN4	ENTRY	Not applicable	
XT3/22	INDAR	EXIT		1) type of output – open collector;
XT3/23	INDAG	EXIT	Used for control of LED displays	2) peak voltage on privacy key 30V; 3) peak current of public key 2A;
XT3/24	INDBR	EXIT		4) resistance of public key 0,1Ohm
XT3/25	INDBG	EXIT		
XT3/26	PSW1	EXIT		1) type of output – open emitter;
XT3/27	PSW2	EXIT	Used for energizing of external units	2) voltage on output in ON state 12V; 3) peak current consumed from the output 1A; 4) resistance of public key 0,25Ohm
XT3/28	RSB		Used for data transmission via serial port	Interface RS-485
XT3/29	RSA			Interface RS-485
XT3/30	SH		RS-485 SCREEN	

End of the Table 6

Connector/contact No.	Description	Direction	Designation	Signal description and parameters
XT4/31	- MGA	EXIT	Used for control of solenoids of rotor mechanism	1) type of output – open collector; 2) peak voltage on privacy key 50V; 3) peak current of public key 9A; 4) resistance of public key 0,11Ohm
XT4/33	- MGB	EXIT		
XT4/32	+ MGA		Connection of cathodes of protective diodes to positive output of solenoids power supply	
XT4/34	+ MGB			
XT5/35	+ 12V			1) voltage 12V; 2) consumption current < 150mA
XT5/36	+ 12V			
XT5/37	+ 12V			
XT5/38	GND (common)			
XT5/39	GND (common)			
XT5/40	GND (common)			

1.6.2 Controller PCB.201.01.00.00

1.6.2.1 The Controller PCB.201.01.00.00 is designed for motor control of motorized turnstile. The Controller is assembled on the (85x70)mm card, on which electronic components and connectors for external connections are installed.

On controller card 13 LEDs are installed. Their purpose is as follows:

- 8 LEDs indicate condition of inputs «IN1» ÷ «IN8»;
- «POWER» LED indicates availability of supply voltage 5V;
- 4 LEDs indicate condition of outputs for connection of motor.

24 terminals are installed on the card: 2 of them are designed for external connections, the rest are designed for connection to turnstile units or are standby.

Appearance of the controller is shown in the Figure 3.

1.6.2.2 Technical features

The controller technical features are specified in the Table 7.

Table 7

Parameter description	Parameter value
Number of inputs for reception of control commands	2
Number of signal outputs	4
Type of inputs	logical
Type of outputs «GRN1», «RED1», «GRN2», «RED2»	open collector
Logical «1» voltage	(3,7÷5)V
Logical «0» voltage	(0÷1,7)V
Peak voltage applied to inputs «IN1»÷« IN8», maximum	15V
Peak voltage switched by outputs «GRN1», «RED1», «GRN2», «RED2»	30V
Peak current switched by outputs «GRN1», «RED1», «GRN2», «RED2»	2A
Peak voltage switched by outputs «-MG1», «-MG2»	50V
Peak current switched by outputs «-MG1», «-MG2»	5A
Peak voltage switched by outputs «MOT1», «MOT2»	27V
Peak current switched by outputs «MOT1», «MOT2»	≤ 4A
Controller supply voltage	(10÷27)V
Consumption current when outputs «MOT1» and «MOT2» are OFF	≤0,15A
Climatic version and placement category of according to the GOST 15150-69	NF4

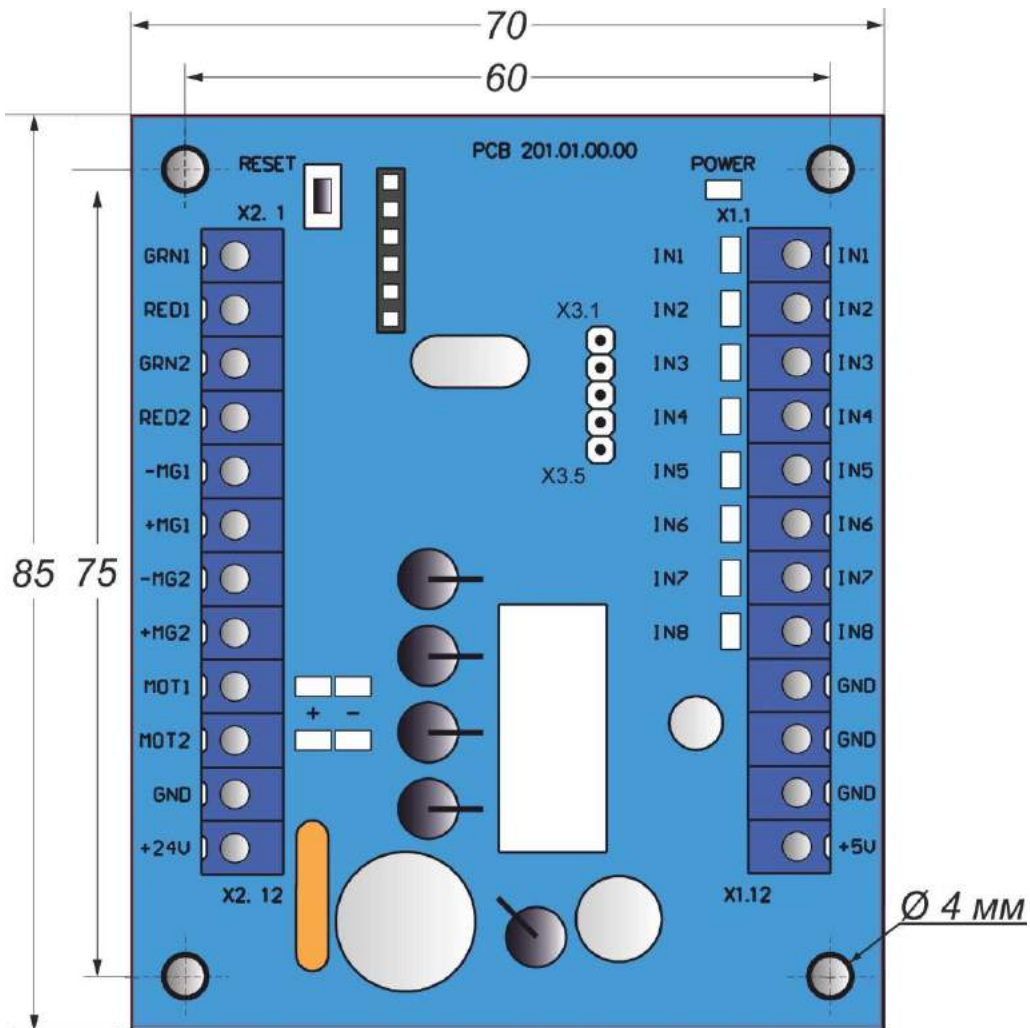

Figure 3 – Appearance of the controller PCB.201.01.00.00

1.6.2.3 Description of operation

Controller operates according to the program entered into memory of microprocessor. Motor is controlled depending on commands coming from the controller PCB.112.21.20.00,

position of rotor, rotation speed based on the logic downloaded into program. Control commands are generated to controller via serial interface. During energization controller turns rotor to initial position. Waiting for permission command controller keeps rotor in initial position. After permission command is sent and rotor is gently pushed by hand in direction of access via outputs «MOT1» and «MOT2» (X2/9 and X2/10) current is fed to motor winding and rotor is turned in the appropriate direction. Speed and position of rotor is controlled during rotation. After pedestrian turnstile access rotor continues to turn smoothly forward (turn additionally), gradually slowing down, and when the angle 120° is reached rotor is held in this position by means of servomotor.

Purpose of controller's contacts designed for connection of peripherals is shown in the Table 8.

Table 8

Connector / contact No	Designation	Direction	Description	Signal parameters and description
XT1/1	INP1	ENTRY	Not applicable	1) logical «0» (0÷1,7)V;
XT1/2	INP2	ENTRY		
XT1/3	INP3	ENTRY	Signal of mechanical unlocking	2) logical «1» (3,7÷5)V;
XT1/4	INP4	ENTRY		
XT1/5	INP5	ENTRY	To be connected to the rotor position sensor and motor speed sensor	3) active level of signal (factory setting) – logical «0»;
XT1/6	INP6	ENTRY		
XT1/7	INP7	ENTRY		
XT1/8	INP8	ENTRY		
XT1/9	GND		«-» power supply (common wire)	
XT1/10	GND			
XT1/11	GND			
XT1/12	+5V	EXIT	Not applicable	
XT2/1	GRN1	EXIT	Not applicable	
XT2/2	RED1	EXIT		
XT2/3	GRN2	EXIT		
XT2/4	RED2	EXIT		
XT2/5	-MG1	EXIT	Not applicable	1) type of output – open collector; 2) peak voltage on privacy key – 50V; 3) peak current of public key – 5A
XT2/6	+MG1	EXIT	Not applicable	
XT2/7	-MG2	EXIT	Not applicable	1) type of output – open collector; 2) peak voltage on privacy key – 50V; 3) peak current of public key – 5A
XT2/8	+MG2	EXIT	Not applicable	

XT2/9	MOT1	EXIT	Connection of motor	1) voltage (10÷27)V; 2) current ≤ 4A
XT2/10	MOT2	EXIT		
XT2/11	GND		«-» power supply (common wire)	
XT2/12	+24V	ENTRY		1) voltage (10÷27)V; 2) current ≤ 4A

2 INTENDED USE

2.1 Operation limitations

2.1.1 The turnstile must be used in the environment specified in the p. 1.1.4 of this document subject to the specifications listed in the section 1.2



IT IS PROHIBITED:

- 1) **UNINTENDED USE OF THE TURNSTIL** (see the Chapter 1 «DESCRIPTION AND OPERATION»);
- 2) **TO USE THE TURNSTILE UNEARTHED;**
- 3) **TO USE HEATING PIPES AND RADIATIONS AS WELL AS PIPES OF CENTRAL WATER SUPPLY FOR EARTHING;**
- 4) **TO REPAIR AND ADJUST WITHOUT DEENERGIZING.**

2.1.3 It is not allowed to use the turnstile:

- at the presence of mechanical rattle in movable parts of the turnstile;
- when metalwork of the turnstile and its components and accessories are mechanically damaged.

2.1.4 List of special conditions of operation

- Mean time of pedestrian turnstile access (in single access mode) equals to 3 sec.
- The turnstile mechanism enables to perform emergency unlocking with the use of key.
- The force applied by accessor to the center of barrier rod should not exceed 600 H.
- Escape door, portal or pedestrian gate can be installed near the turnstile to grow the turnstile traffic flow capacity growth in case of emergency.



ATTENTION: MANUFACTURER WARNS OF NECESSITY TO KEEP SEALS OF THE MANUFACTURER ON THE TURNSTILE'S COMPONENT PARTS!

2.2 Layout and installation

2.2.1 The turnstile and components of delivery kit are delivered to the installation site in the factory packing. The turnstile should be unpacked only on installation site.

2.2.2 Preparation of the turnstile for installation (dismounting) and commissioning should be performed according to this OM with mandatory observation of the safety measures specified in p. 2.1 and general electrical safety code.

2.2.3 The turnstile should be installed in the following sequence:

- inspect the turnstile for integrity, absence of visual damages and defects;
- verify the turnstile's completeness;
- prepare installation site for mounting of the turnstile: surface should be plain, hard and without defects (corrugations, overlaps etc.);
- prepare cable conduits and holes for the turnstile fixation;

General view of the assembly

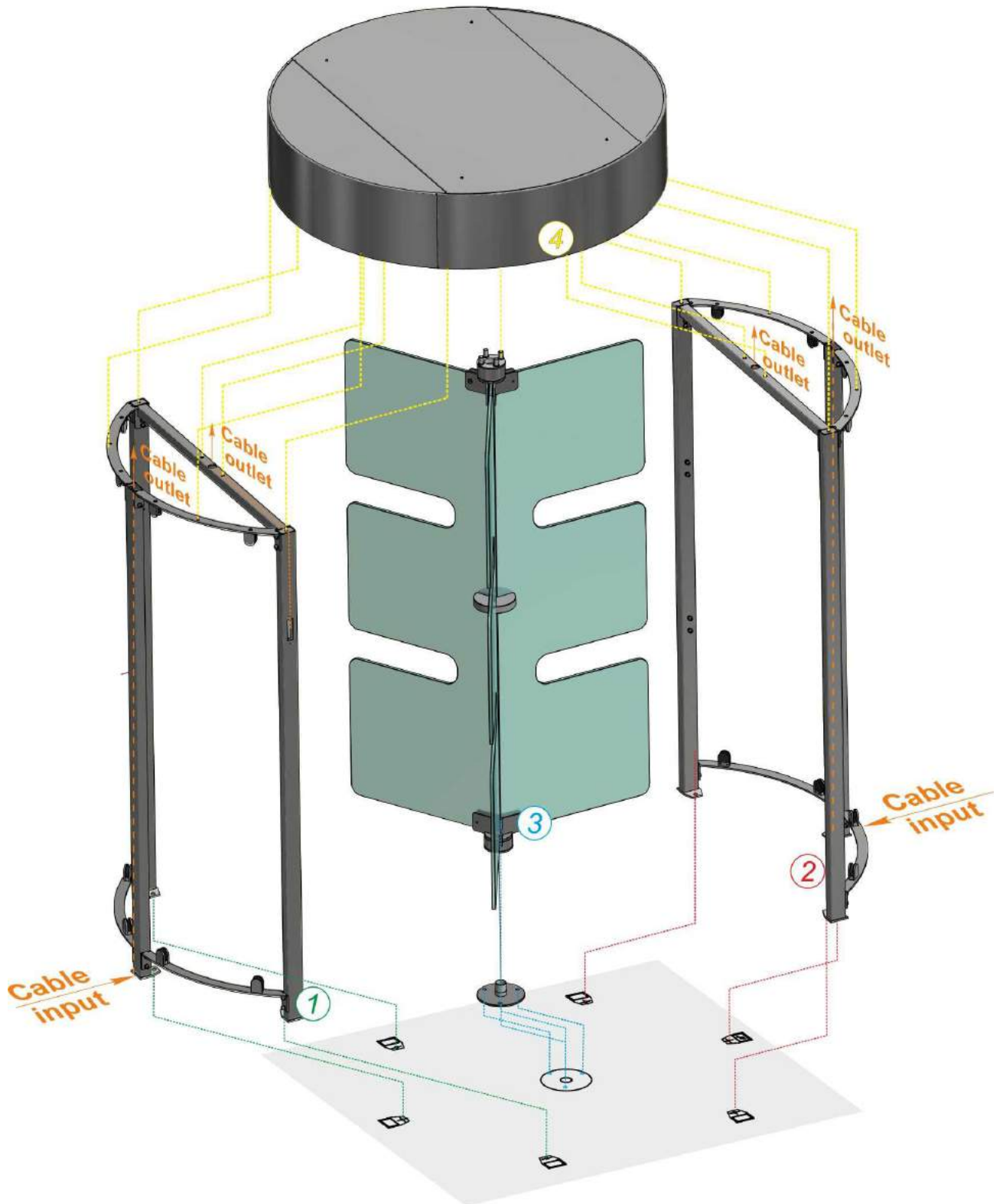

–walls and rotor are installed and fixed on the frame to be installed on prepared site. Roof is installed on the top. Control mechanism and rotor are aligned as per single axis and connected by means of half-coupling. For proper installation the rotor should be turned so that a glass blade aligned with rotor pin as per single axis bars the turnstile access, i.e. rotor corresponds to the turnstile position «CLOSED» (see the Appendix A).

Installation and fixation of the turnstile should be performed only after pulling of all the turnstile electrical connection cables. The turnstile should be fixed on installation site by means of Redibolt (anchor with jacket and screw). Make sure of stability of the installed turnstile and after that open both locks of mechanical unlocking by means of keys and check rotor rotation by hand: rotor should easily rotate to both sides.

Fixation of structure, final installation of smaller units and wiring should be performed according to the wiring diagram (see the Appendix C);

–the turnstile should be grounded;

–to actuate the turnstile it is necessary to provide the input of UPS with AC voltage.

1) Assembly and installation of enclosure wall

2) Assembly and installation of passage wall

3) Assembly of a rotor

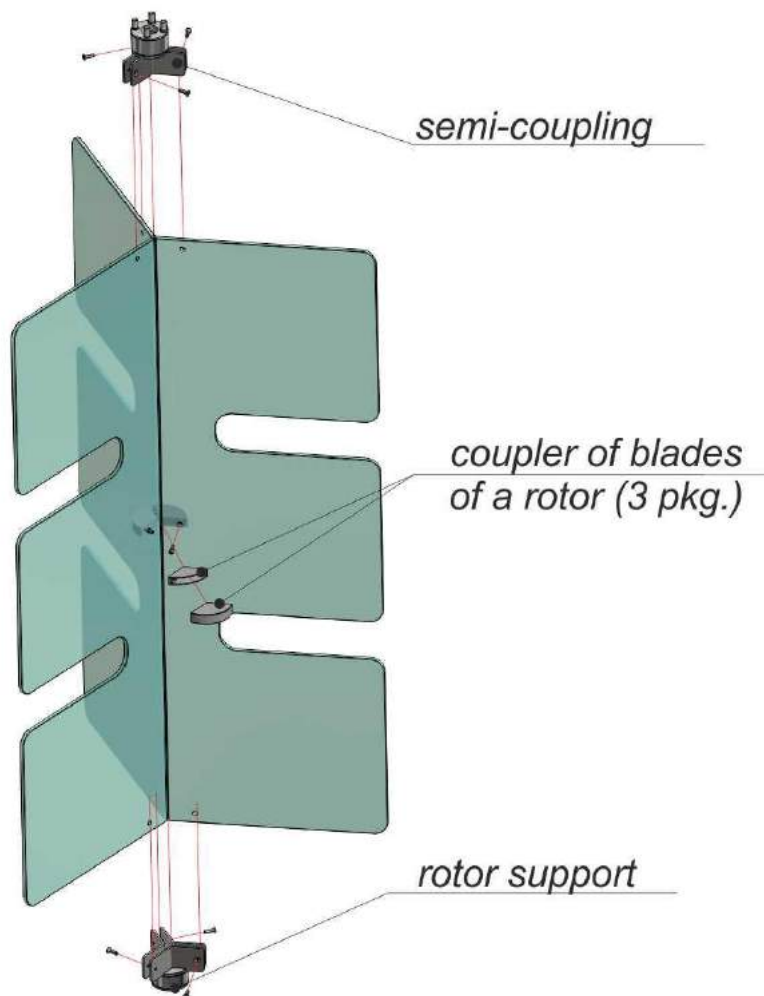

4) Installation of a container and of a rotor

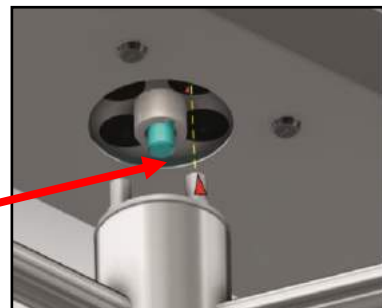
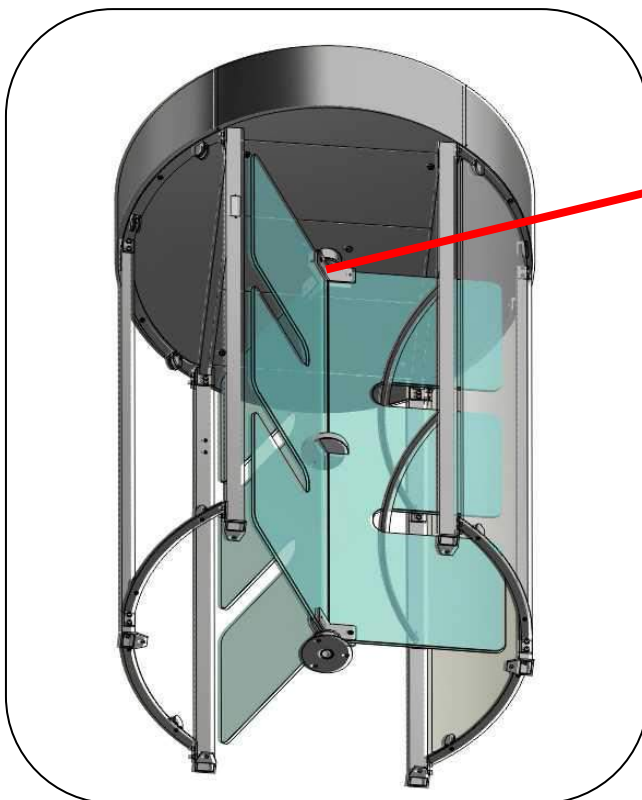
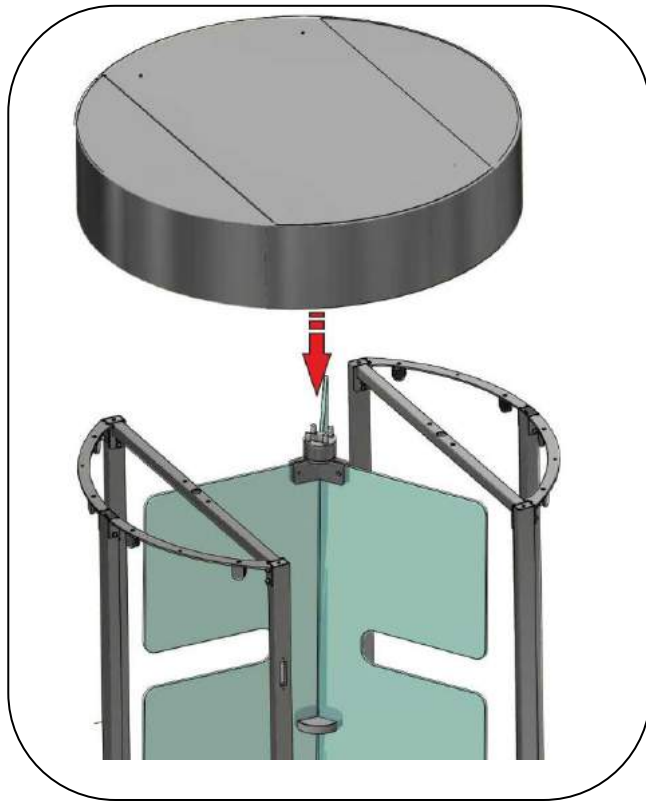

Fastening with screws:

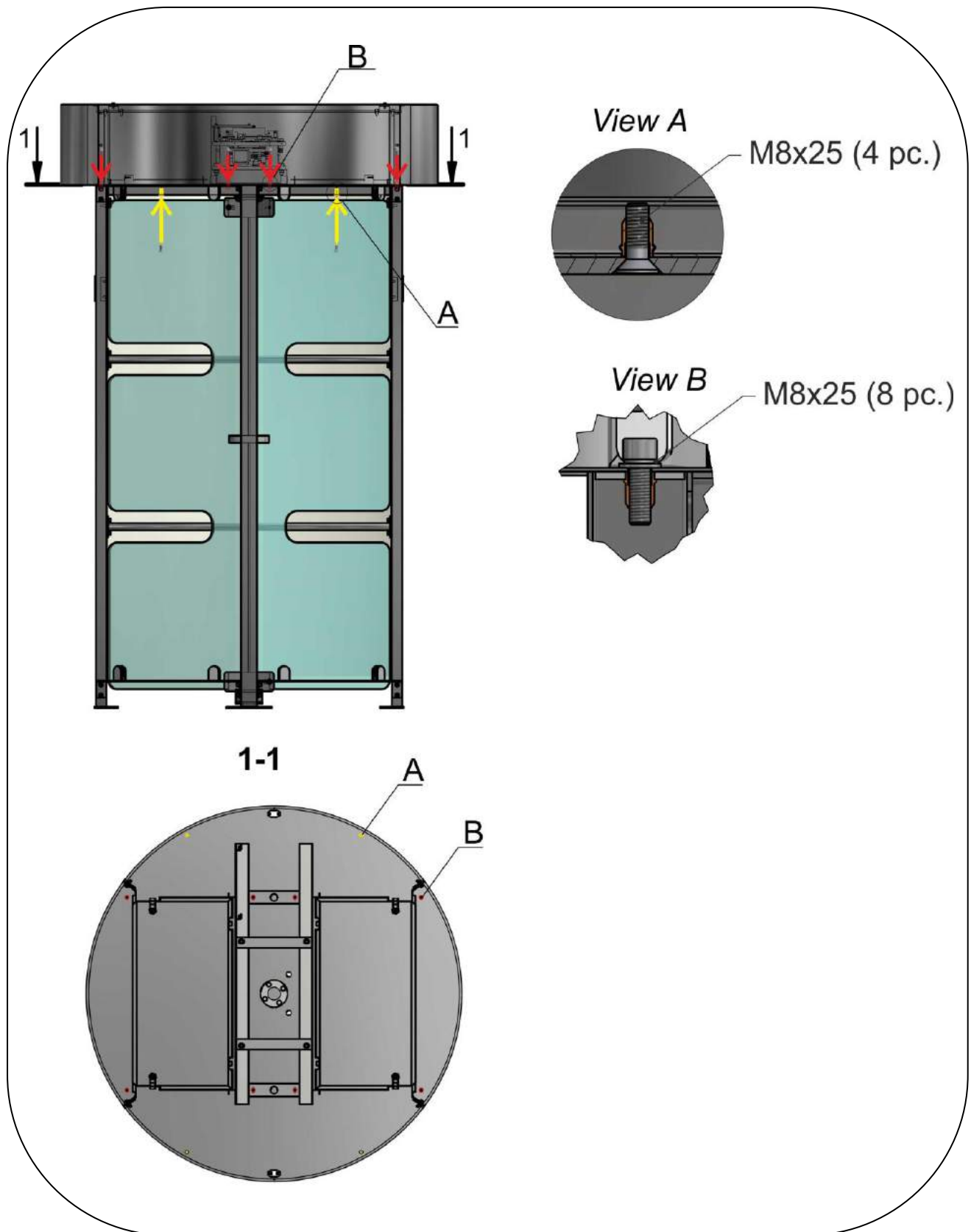

5) Wall glass and framework arch installation

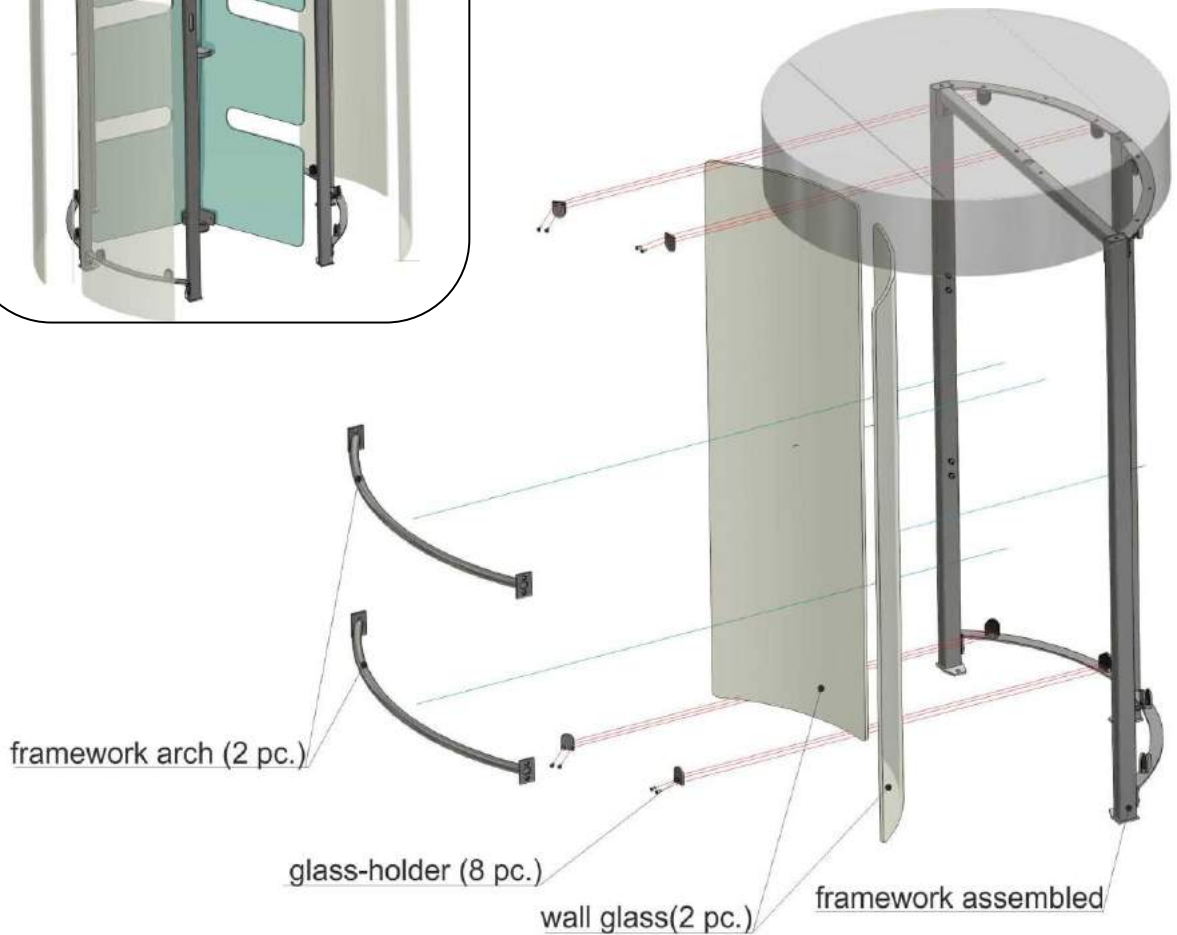
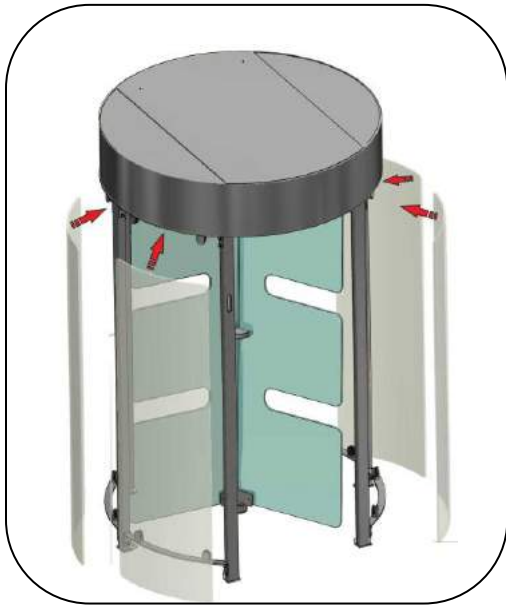

2.3 Preparation for use

2.3.1 Commissioning instructions

Prior to energizing of the turnstile:

- 1) make sure of proper connection and good condition of all connecting cables;
- 2) clear the rotor rotation area from foreign particles;
- 3) verify by keys that locks of the turnstile mechanical unblocking are closed (turnstile is mechanically locked).

When mains cable of power supply unit is connected to the network, solenoids of the turnstile control mechanism are energized, rotor is locked from rotation in both directions barring access.

The turnstile is set in initial state and is ready for operation: entry and exit LED displays are red (« » is lit).

2.3.2 Required inspections

2.3.2.1 When the turnstile is commissioned it is necessary to perform inspections specified in the Table 9. During inspections the wiring diagram according to the Appendix C and the control panel according to the Appendix B should be used.

Table 9

Operation Mode	Mode Setting	LED Display
1 Turnstile is closed in both directions (initial state)	–	Red LED display is lit
2 Single access in one direction	Push the «SINGLE» access button to access in selected direction («A» or «B»)	Green arrow of single access is lit in chosen direction and red LED display is lit in opposite direction
3 Single access in both directions	Push both «SINGLE» access buttons to access in two directions («A» or «B»)	Green arrows of single access are lit in both directions
4 Free access in one direction	Push the «FREE» access button to access in the selected direction («A» or «B»)	Green arrow of free access in chosen direction is blinking and red LED display is lit in opposite direction
5 Free access in both directions	Push both «FREE» access buttons to access in two directions («A» or «B»)	Green arrow of authorized free access is blinking in chosen direction and green arrow is blinking
6 Single access in one direction and free access in opposite direction	Push the «SINGLE» access button to access in the selected direction and «FREE» access button to pass in opposite direction	Green arrow of authorized single access is lit in chosen direction and green arrow of authorized free access is blinking in opposite direction
7 Single access in one direction and locked access in opposite direction	Push the «SINGLE» access button to access in the selected direction («A» or «B») and the «LOCK» button to lock access in opposite direction	Green arrow of authorized single access is lit in chosen direction and red LED display is blinking in the locked access direction

End of the Table 9

Operation Mode	Mode Setting	LED Display
8 Free access in one direction and locked access in opposite direction	Push the «FREE» access button to access in selected direction («A» or «B») and the «LOCKING» button to lock access in opposite direction	Green arrow of authorized free access is blinking in chosen direction and red LED display is blinking in the locked access direction
9 Locked access in one direction	Push the «LOCKING» button to lock access in selected direction («A» or «B»)*	Red LED display of locked access in one chosen direction is blinking
10 Locked access in both directions	Push both «LOCKING» button to lock access in two directions («A» or «B»)**	Red LED display of locked access in both directions is blinking
* In this case other control panel buttons of single and free access in chosen direction are locked		
** In this case all control panel buttons of single and free access in both directions are locked		

2.3.2.2 The turnstile is ready for long-term operation.

2.4 Contingency actions

In case of emergency evacuation from rooms and provision of free personnel exit the turnstile can be unlocked from control panel by sending the relevant command or manually by turning locks with key in the bottom part of container.

3 MAINTENANCE

3.1 General instructions

3.1.1 Commissioning and subsequent maintenance of the turnstile should be performed only by the staff to be in charge of the turnstile.

3.1.2 The turnstile can be serviced only by the staff having the relevant electrical safety qualification level according to the national requirements.

3.1.3 The turnstile should be installed and operated only by the qualified safety instructed staff having the relevant class of permit to work with electrical facilities with voltage up to 1000V, being aware of this OM, design and the turnstile's principle of operation.

3.2 Safety Measures

3.2.1 During maintenance of the turnstile the relevant safety measures, specified in p. 2.1, must be observed.



IT IS FORBIDDEN TO USE DEFECTIVE APPLIANCES, TOOLS, FUSES, INSTRUMENTATION SERVICE LIFE OF WHICH EXPIRED. MEASURING DEVICES, WHICH TERM OF CHECKING EXPIRED.

3.2.2 When instrumentations are prepared for operation it is necessary to comply with the safety requirements specified in instrumentation instruction manuals..

3.3 Maintenance procedure

3.3.1 Maintenance of the turnstile includes preventive measures which are taken according to established frequency to maintain the turnstile in operational condition, decreasing of component wearing and prevention of faults and malfunctions.

3.3.2 Daily and periodic maintenance of the turnstile are recommended.

Normally the daily maintenance is carried out before the beginning of work or during operational timeout and includes visual inspection of the turnstile's housing, and.



IT IS FORBIDDEN TO USE ABRASIVE AND CHEMICALLY ACTIVE SUBSTANCES DURING CLEANING OF CONTAMINATED EXTERNAL SURFACES OF THE PRODUCT

The recommended stainless steel detergents are given in Table 10.

Table 10

<i>Detergent description</i>	<i>Manufacturer</i>	<i>Country of origin</i>
Stainless steel cleaning spray “Stainless Steel Cleaner And Polish”	3M	Group of European companies
Cleaning fluid “Well Done”	Well Done	Hungary
Stainless steel products and other metals cleaner “XANTO STEEL 3in1”	XANTO	United Kingdom
«Dr.BECKMANN»	Dr.Beckmann	Germany
Cleaning solution “Reinex Edelstahlreiniger”	Reinex	Germany
Cleaning spray “Stainless steel cleaner”	Onish	United Kingdom

3.3.3 Periodic maintenance for the purpose of troubleshooting includes as follows:

- monthly periodic maintenance (maintenance-1): visual inspection of control mechanism for the present of deformations and other defects, checking of soft movement of latches and absence of jamming and gripping, checking of correct traveling of closer. Furthermore, optocouplers 18, 19 and sprocket disks 16, 17 are inspected (see the Figure 1). Optocouples’ gap and sprocket disk surfaces are cleaned from dust and dirt and tightening of screw fastenings of turnstile units to frame, if necessary;
- semiannual periodic maintenance (maintenance-2) includes all activities of the maintenance-1 as well as checking of solenoid consumption current, the value of which should not exceed 2,5A in the sucking mode and 0,15A in retention mode, lubrication of latch axes of with grease lubricant of solid oil type;
- annual periodic maintenance (maintenance-3) includes all the maintenance-2 activities as well as the following:
 - 1) checking of fixation of optocouplers 18, 19 and functional gap size in relation to the disk;
 - 2) checking of optocouplers 18, 19 regarding the absence of alarm related to movement during swinging of rotor shaft in both sides until latches touch functional surfaces of ratchet gears;
 - 3) checking of status of pressure rollers of microswitches 27 and 28 as well as replacement of microswitches, if necessary;
 - 4) checking of status of roller 13 and its replacement, if necessary;
 - 5) checking of status of grommets connecting rotors and control mechanism and their replacement, if necessary..

4 ROUTINE MAINTENANCE

4.1 General instructions

Possible malfunctions of the turnstile listed in the Table 10 are remedied by the customer. More complicated malfunctions are remedied by manufacturer’s representative.



ATTENTION: INSPECTION, CLEANING, REPAIR OF THE TURNSTILE’S COMPONENTS MUST BE PERFORMED ONLY AFTER DEENERGIZING OF THE TURNSTILE!

4.2 List of possible malfunctions

List of possible malfunctions and their remedies are specified in the Table 1.

Table 11

Symptom	Possible cause	Remedy
1 Increased vibration during turnstile operation	Tightening of arched structure screw joints is loosened	Screw joints of framed elements to be tightened
	Bearing of rotor support is out of order	Bearing to be replaced
2 LED display does not operate in the preset mode	Electric circuit is broken	Malfunction to be identified and remedied
	Fault of controller operation	Supplier to be consulted
	LED is out of order	LED to be replaced
3 Turnstile does not provide unlocking of rotor	Voltage on solenoids is absent	Voltage 12V in circuit of solenoids to be checked. If voltage is lower than 12V – refer to p.4 of this table
	Electric circuit is broken	Malfunction to be detected and remedied
	Solenoid is out of order	Solenoid to be replaced
	Adjustment of solenoid is disrupted	Stroke of solenoid stem to be adjusted
4 Voltage 12V is not provided	Power supply unit is out of order	Power supply unit to be replaced
	Electric circuit is broken	Malfunction to be detected and remedied
	Low voltage in circuit	Voltage in the power network to be checked and origin of voltage drop to be remedied

4.3 Postrepair checkout

The turnstile performance is checked after repair according to p. 2.3.2 of this OM.

5 TRANSPORTATION AND STORAGE

5.1 Turnstile storage

It is forbidden to subject the turnstile to jerks and impacts during storage. Transportation trolleys to be used for handling of the turnstile. In storage facilities there should not be aggressive gases and vapours causing metal corrosion.

Air temperature during storage should not be below +50° C and above +40° C and relative air humidity should not be more than 80% at the temperature 20° C.

5.2 Turnstile transportation

The ready-to-install turnstile to be transported according to the transportation regulations related to the relevant mode of transport, such as:

- in railway or special containers;
- in closed vehicles;
- waterborne (in ship's hold) .

Air temperature during transportation should not be below -40°C and above +50°C.

After transportation or storage of the turnstile at negative temperatures or increased humidity the turnstile to be kept indoor with normal climatic conditions without original packing within 12 hours before commissioning:

- 1) ambient temperature: + 15°C to +35°C;
- 2) relative humidity: 45% to 80 %;
- 3) atmospheric pressure: 84,0 to 106,7kPa (630-800 mm Hg).

6 DISPOSAL

The turnstile design does not contain materials environmentally hostile and hazardous to health and special measures are not required for its disposal.

7 MANUFACTURER'S WARRANTY AND TERMS OF WARRANTY MEAINTEANCE

7.1. The manufacturer guarantees good state and declared quality of the turnstile if conditions of transportation, storage, installation and operation are observed by the consumer

7.2. The warranty period of the turnstile from the date of sale is **12 months** unless otherwise specified by agreement.

7.3 During warranty period the Manufacturer undertakes to perform repair or replacement within 10 days (at the discretion of the Manufacturer) of the failed turnstile or its parts having proven factory defects (not due to nonobservance of storage, transportation, installation and operation conditions specified by this OM) preventing further use of the turnstile.

7.4 The Manufacturer does not bear responsibility and warranty liabilities for the turnstile damage due to nonobservance of the requirements specified by this OM and in case of the turnstile unintended use.

7.5 Warranty liabilities of the Manufacturer are valid only if sections 3, 4, 5 of this DATASHEET and warranty coupon are completed as well as the relevant signatures and seals are available. The turnstile to be repaired only by the authorized service center of the manufacturer with use of exclusively original spare parts. Warranty liabilities don't include free-of-charge arrival of technical staff to the Customer for repair.

7.6 The relationships between the Manufacturer and the Customer under warranty liabilities are regulated by the applicable law of Ukraine, concluded purchase contracts and these warranty obligations.

Manufacturer:

"TiSO-PRODUCTION" LTD

72 Yamskaya str., 03150 Kiev, Ukraine

Tel.: +38 (044) 291-21-11

Tel./Fax: +38 (044) 291-21-02

E-mail: sales@tiso.global

WEB www.tiso.global

Our equipment complies with requirements of the European Standards:

EN 60335-1:2002, EN 61000-6-1:2007; EN 61000-6-3:2007; EN 61000-4-2:2009; EN 61000-4-3:2006; EN 61000-4-4:2012; EN 61000-4-5:2006; EN 61000-4-11:2004

and is in conformity with requirements of the following EC Directives:

2014/30/EC; 2014/35/EC; 2006/42/ EC

The company is certified acc. to - EN ISO 9001:2015 certificate No. HU14 / 7373.03.



QR-code to be used to download the Operation Manual via Internet Приложение А

**Appendix A
(mandatory)**

**Design, overall and fitting dimensions
of Indoor Single Full-Height Turnstile**

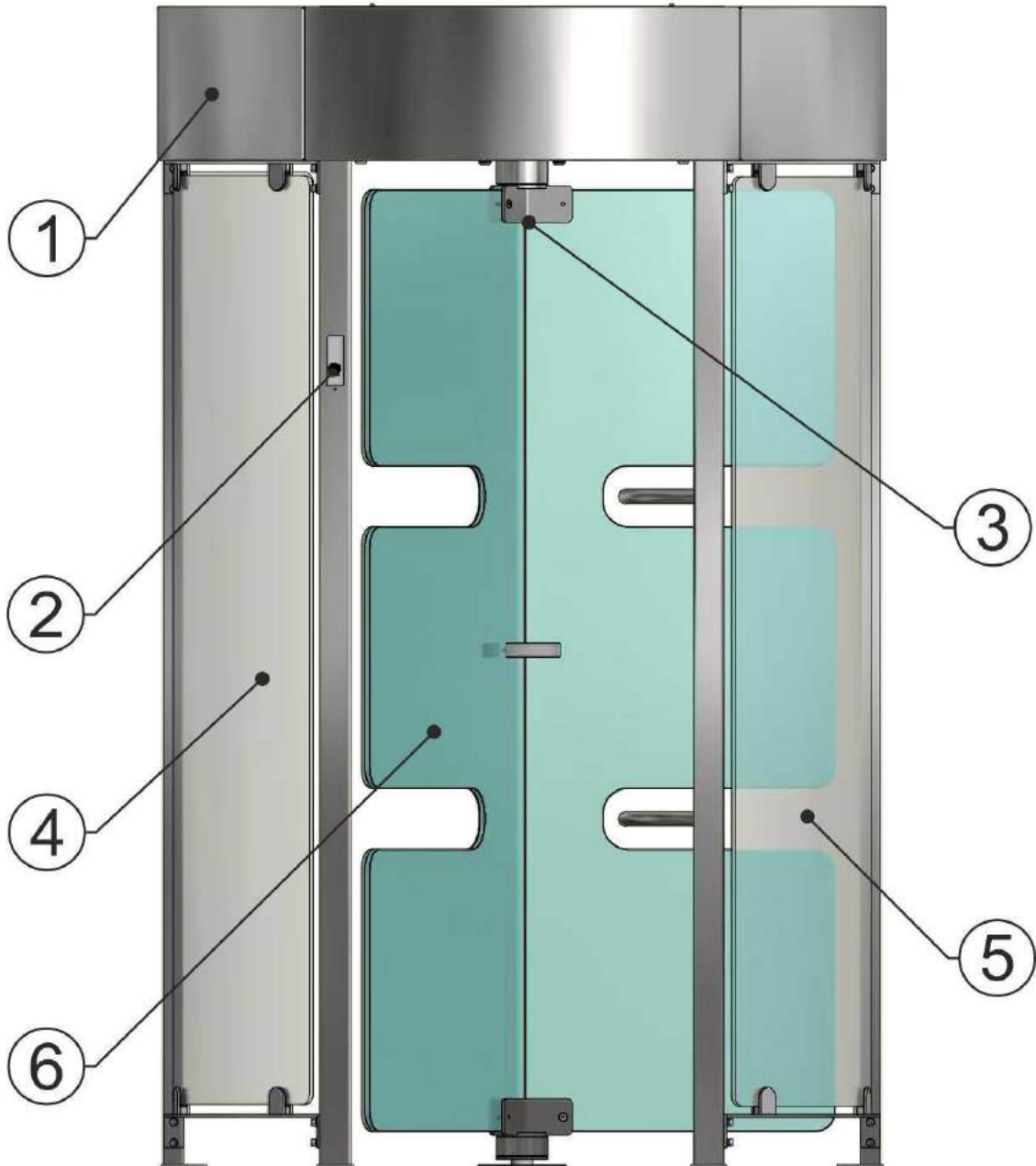

1 – roof;
2 – LED display;
3 – rotor;

4, 5 – wall;
6 – rotor-blade

Figure A.1– Design of Indoor Single Full-Height Turnstile

Annex A(continued)

Design, overall and fitting dimensions
of Indoor Single Full-Height Turnstile

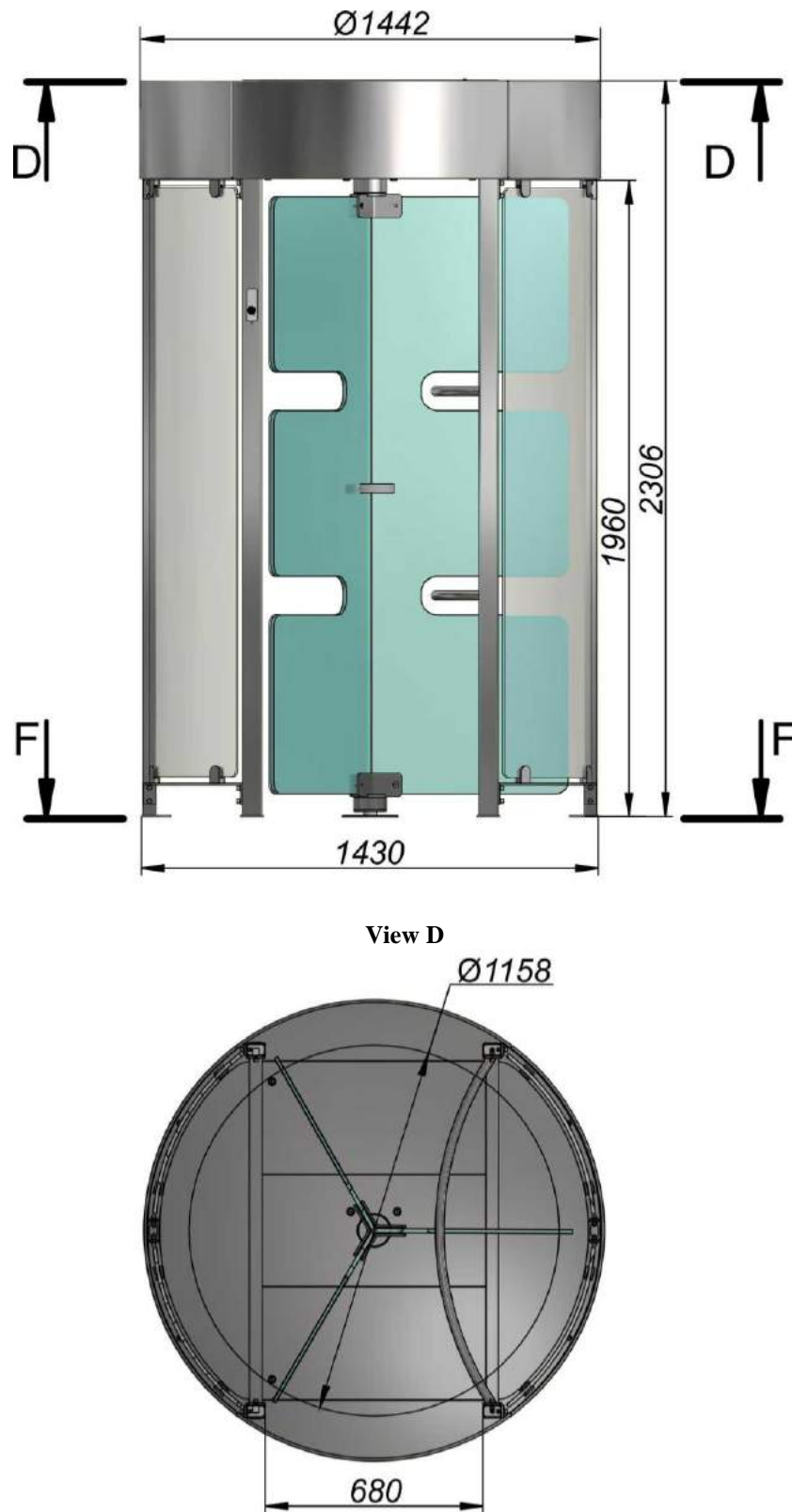

Figure A.2– Fitting dimensions of Indoor Single Full-Height Turnstile

Annex A(continued)

Design, overall and fitting dimensions
of Indoor Single Full-Height Turnstile

View F

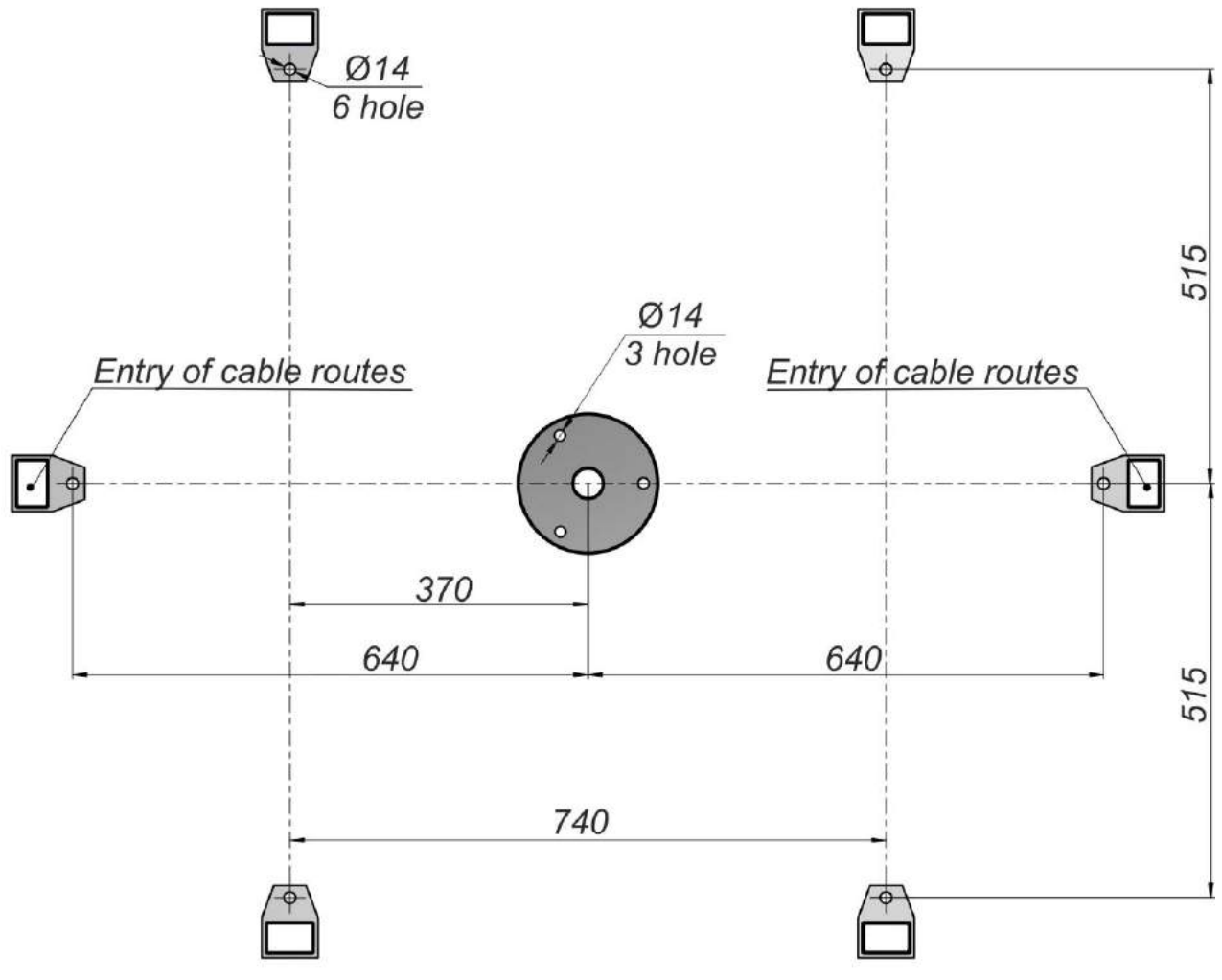
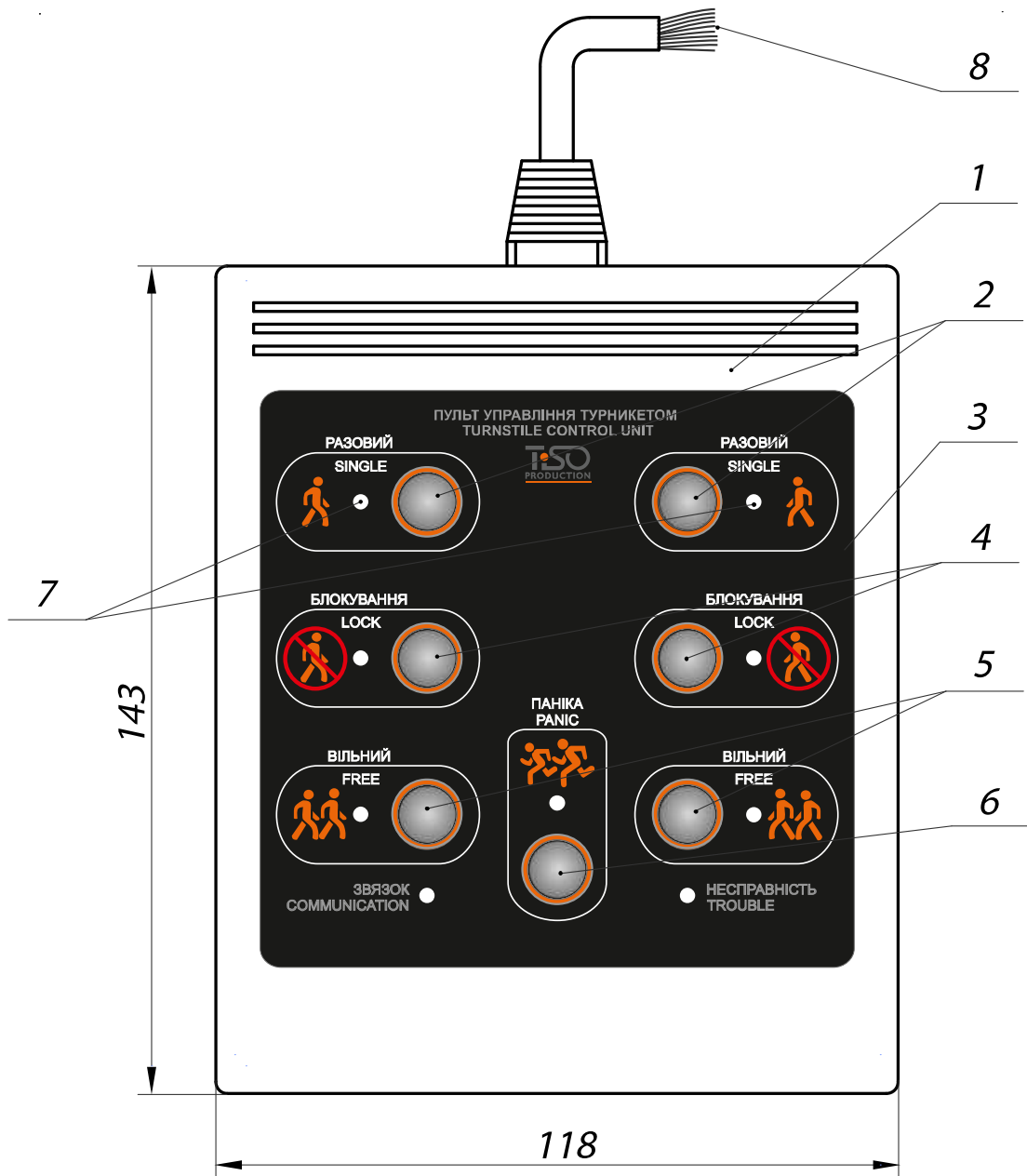

Figure A.3– Assembly drawing of Indoor Single Full-Height Turnstile

Annex B
(mandatory)
Control panel and connection diagram



- | | |
|---|---------------------------------------|
| 1 – control panel body; | 5 – "FREE ACCESS" mode control button |
| 2 – "SINGLE ACCESS" mode control button | 6 – "PANIC" mode control button |
| 3 – front plate; | 7 – access direction LED display; |
| 4 – "LOCK" mode control button; | 8 – controller connection terminals |

Fig. B.1 – Control panel AUIA.114.02.00.00

Continued Annex B
Control panel and connection diagram

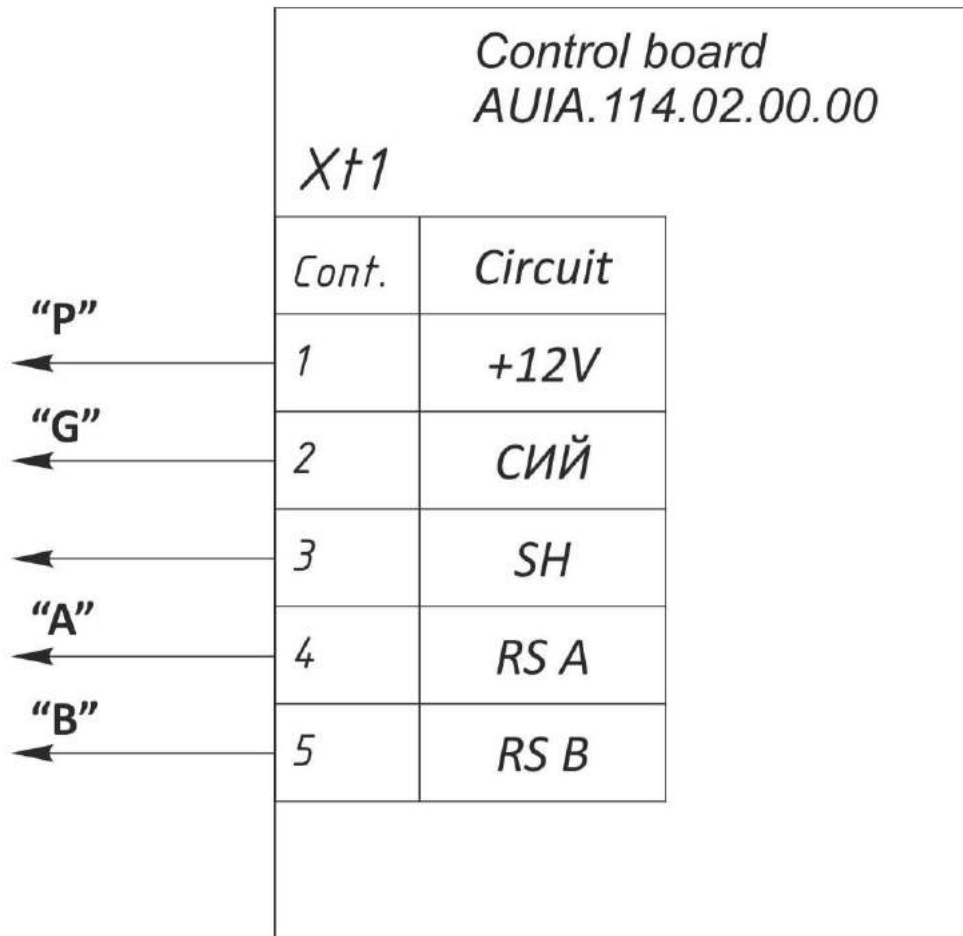

Fig. B.2 – Connection diagram of control panel AUIA.114.02.00.00

Annex B (continued)

Control panel and connection diagram

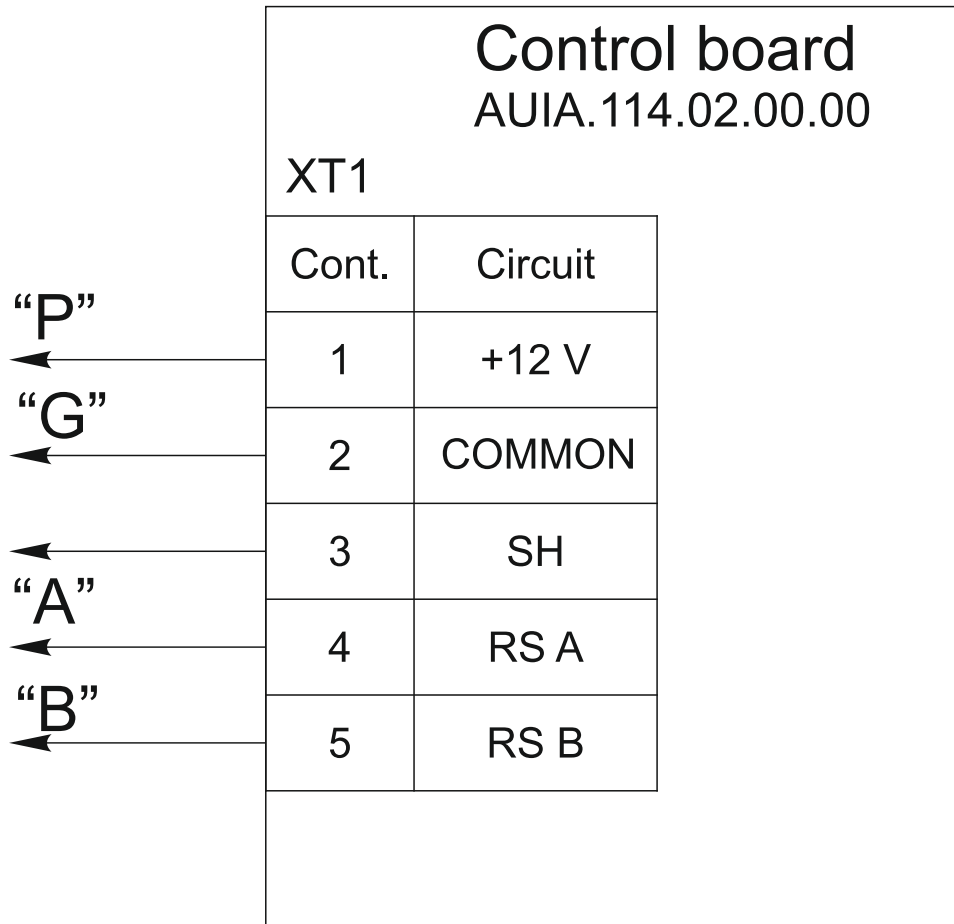
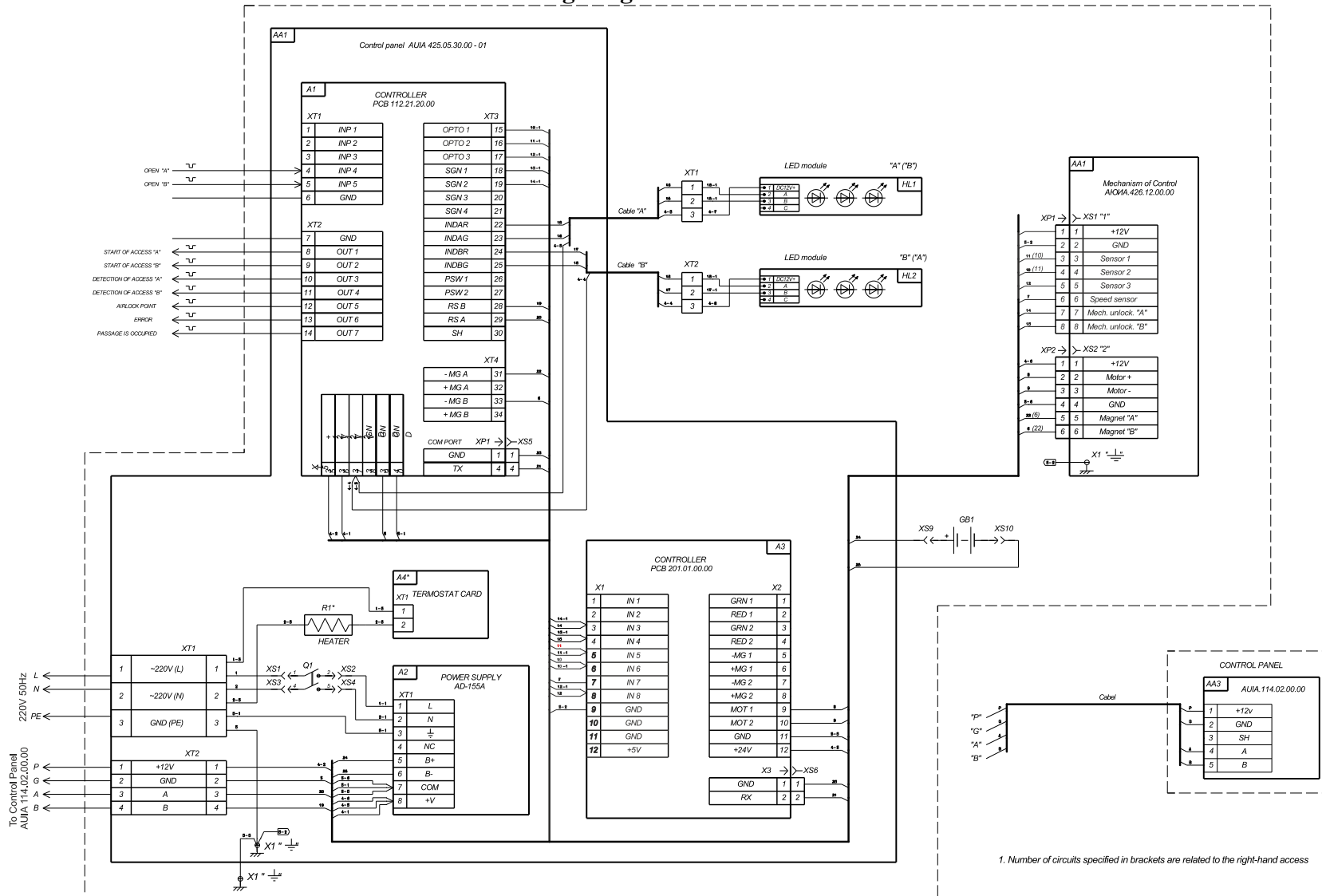

Fig. B.2 – Connection diagram of control panel AUIA.114.02.00.00

Annex C (mandatory) Wiring Diagram of the turnstile



1. Number of circuits specified in brackets are related to the right-hand access

Annex D.1
(mandatory)

Wiring diagram of the turnstile connection to access control system (ACS) in pulse mode

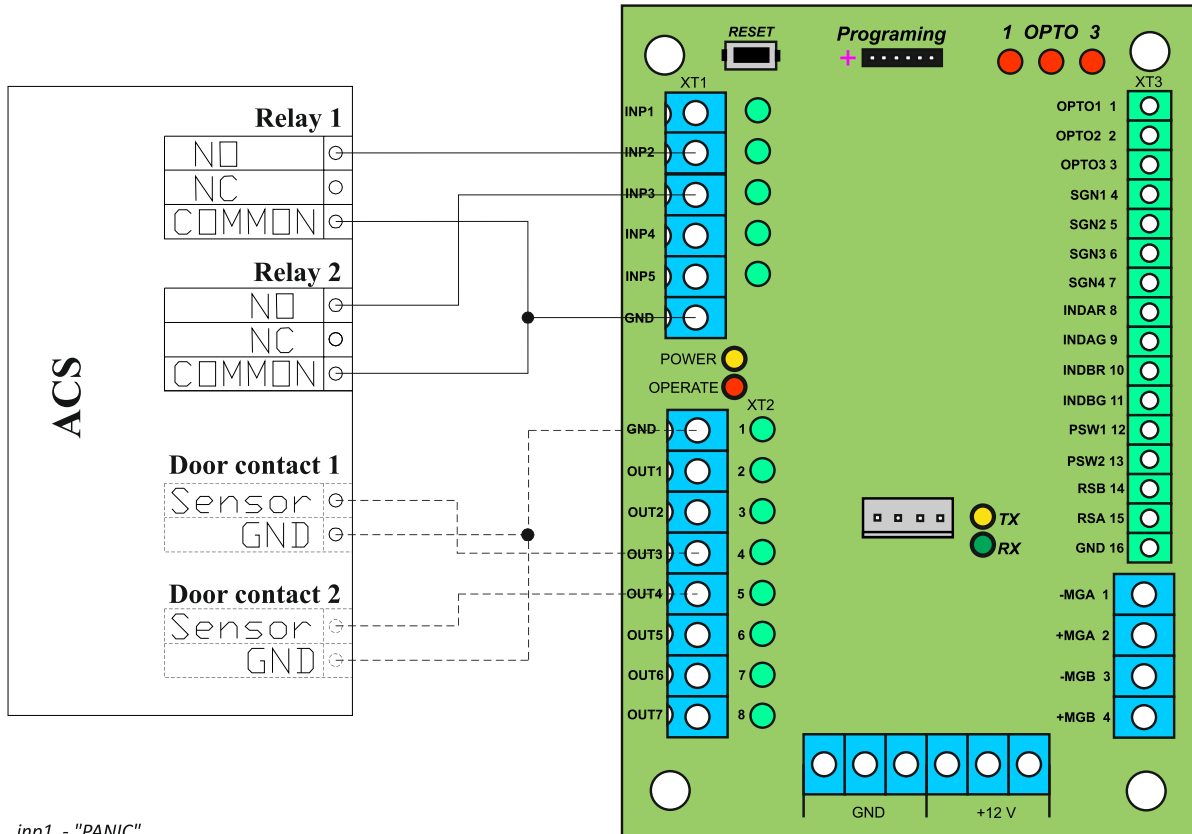

inp1 - "PANIC"

inp2 - "TO BE OPENED A" in pulse mode.

When command is issued entry is activated for 5 sec.

inp3 - "TO BE OPENED B" in pulse mode. When command is issued entry is activated for 5 sec.

inp4 - "TO BE OPENED A". Entry is activated for the time of keeping in active state

inp5 - "TO BE OPENED B". Entry is activated for the time of keeping in active state

GND- "-" of power supply (common wire)

out3 - "DETECTION OF ACCESS A" } Signal is generated by controller when rotor is
out4 - "DETECTION OF ACCESS B" } rotating from 64° to 120° in the relevant direction

Figure D.1 – Wiring diagram of the turnstile connection to ACS

Annex D.2
(mandatory)

Wiring diagram of the turnstile connection to access control system (ACS) in hold mode

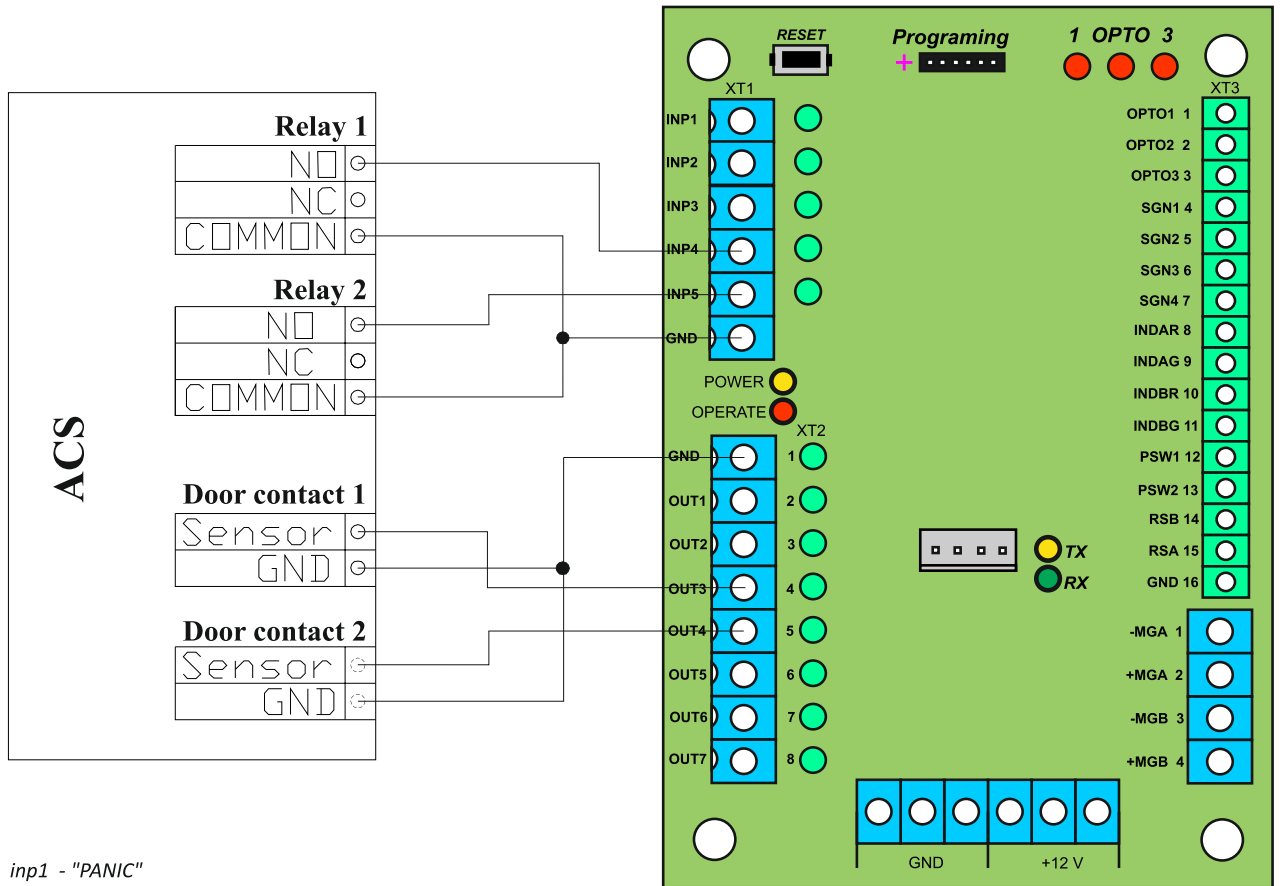

inp1 - "PANIC"

inp2 - "TO BE OPENED A" in pulse mode.

When command is issued entry is activated for 5 sec.

inp3 - "TO BE OPENED B" in pulse mode. When command is issued entry is activated for 5 sec.

inp4 - "TO BE OPENED A". Entry is activated for the time of keeping in active state

inp5 - " TO BE OPENED B". Entry is activated for the time of keeping in active state

GND- "-" of power supply (common wire)

out3 - "DETECTION OF ACCESS A" } Signal is generated by controller when rotor is
out4 - "DETECTION OF ACCESS B" } rotating from 64° to 120° in the relevant direction

Figure D.2 – Wiring diagram of the turnstile connection to ACS

Annex D.3
(mandatory)

Diagram of the turnstile connection to fire alarm (FA)

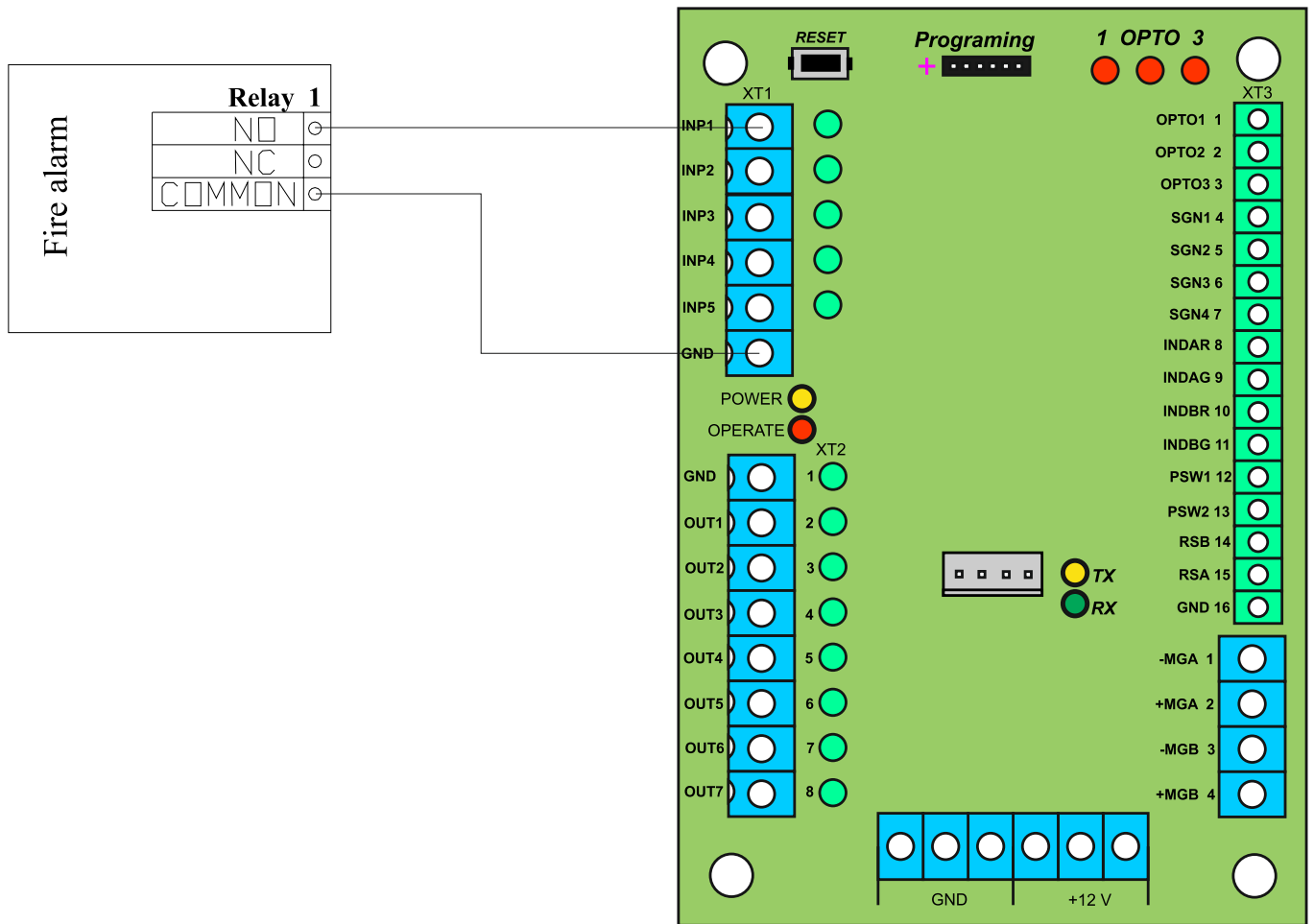

- inp1* - "PANIC"
 - inp2* - "TO BE OPENED A" in pulse mode.
When command is issued entry is activated for 5 sec.
 - inp3* - "TO BE OPENED B" in pulse mode. When command is issued entry is activated for 5 sec.
 - inp4* - "TO BE OPENED A". Entry is activated for the time of keeping in active state
 - inp5* - " TO BE OPENED B". Entry is activated for the time of keeping in active state
 - GND*- "-" of power supply (common wire)
- out3* - "DETECTION OF ACCESS A" } **Signal is generated by controller when rotor is**
out4 - "DETECTION OF ACCESS B" } **rotating from 64° to 120° in the relevant direction**

Figure D.3 – Wiring diagram of the turnstile connection to fire alarm system (FAS)

Annex D.4
(mandatory)

Wiring diagram of the turnstile connection to fire alarm system (FAS)

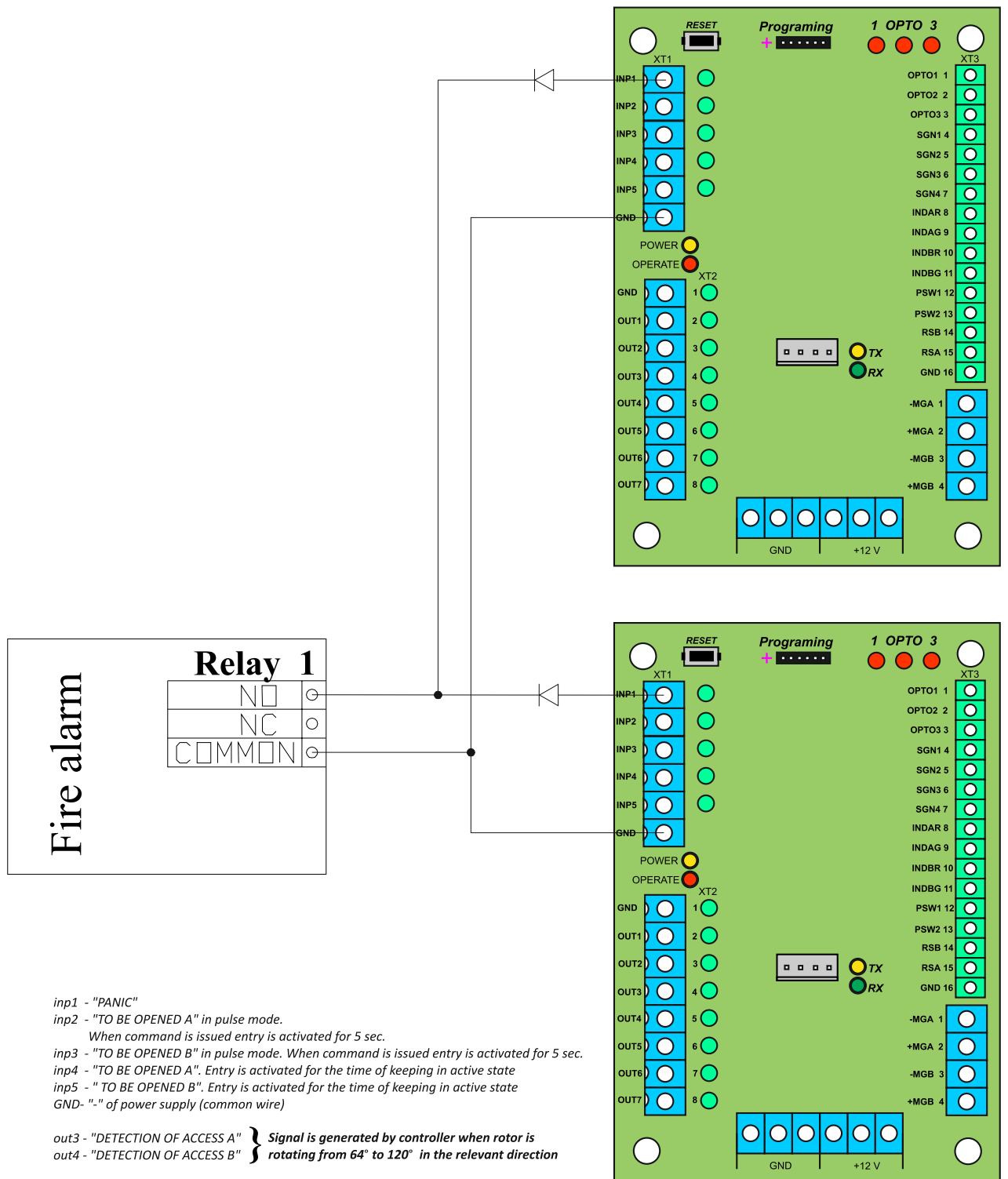

Figure D.4 – Wiring diagram of the turnstile connection to fire alarm system (FAS)

Annex D.5
(mandatory)

Wiring diagram of the turnstile connection to control panel

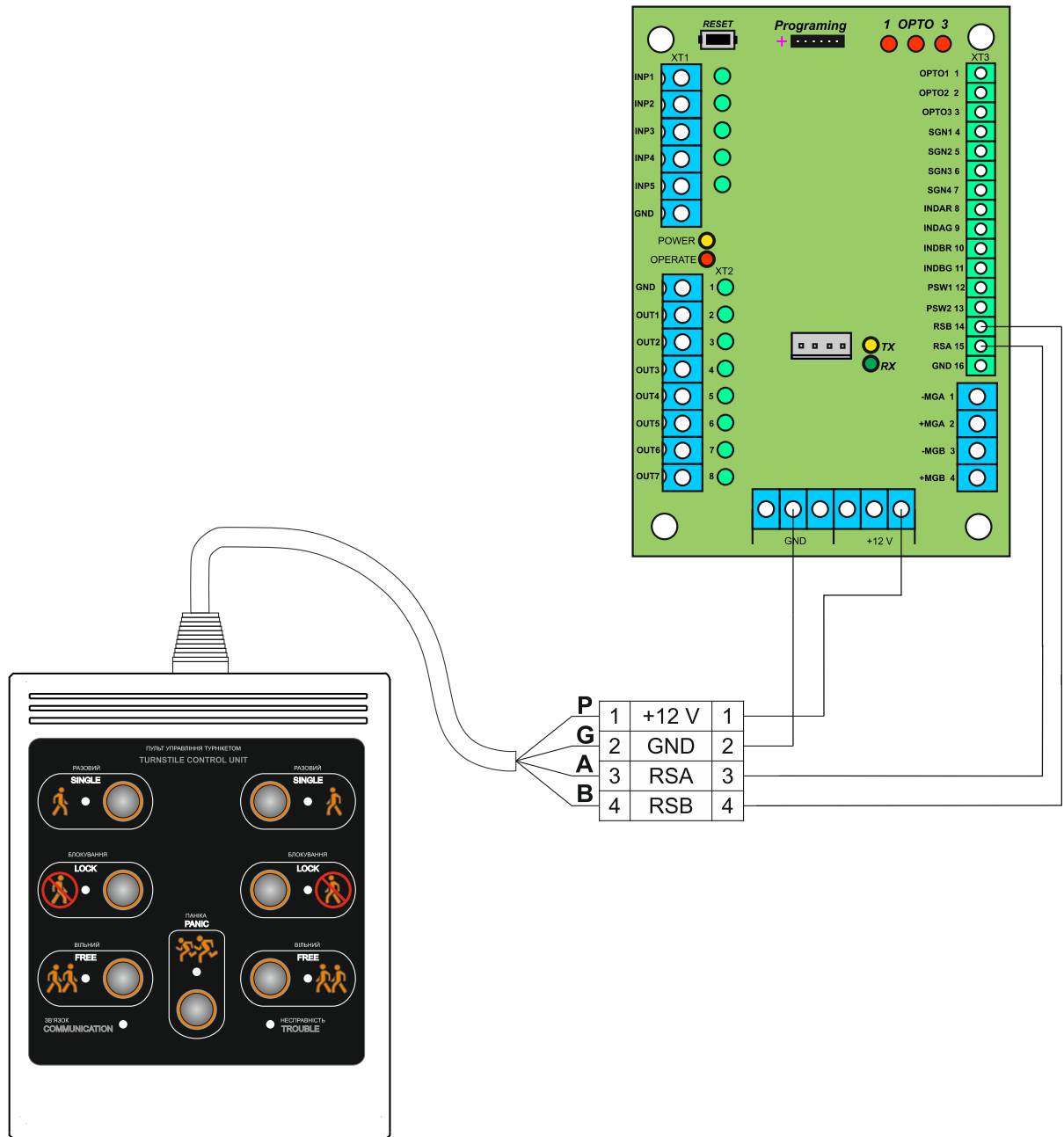

Figure D.5 – Wiring diagram of the turnstile connection to control panel